



CONVEYORS

Up to 815tph/4,500ft³/h (126m³/h)
Lengths to 380' (115.8m)



Performance and reliability – proved in the field
Universal Industries manufactures specialty bulk material handling equipment utilizing slow speeds to handle products that are fragile, abrasive and/or easily fluidized. For the ultimate in gentle handling, you have three choices (photos marked *, **, *** gentle to gentlest) among our elevators. The EASY DUMP™ (*) line has been the standard of the American seed industry for many years. Most models are available in carbon, stainless or galvanized steel.

Universal is the innovator of the Air Vac Cleanout System, which reduces time, labor and cross contamination when changing lots or products. Production savings will pay for the unit quickly.

Universal Industries equipment serves a wide range of markets and industries including seed, nut, grain, fertilizer, foundry, manufacturing, munitions, chemical, spice, pet and livestock food, powdered metal, pharmaceutical, recycling...and many more.



Universal Industries stellt Sonderausrüstung zur Handhabung von Schüttgut her, die langsamen Geschwindigkeiten bei empfindlichem, abrasivem bzw. leicht fluidem Schüttgut verwendet. Für besonders schonende Handhabung können Sie drei Einstellungen aus unseren Senkrechtförderern wählen (siehe mit Sternchen markierte Fotos *, **, *** von schonend bis am schonendsten). Die Reihe EASY DUMP™ (*) ist seit vielen Jahren der Industriestandard der amerikanischen Saatgutindustrie. Die meisten Modelle sind in Kohlenstoffstahl, Edelstahl oder verzinktem Stahl erhältlich.

Universal Industries ist der Erfinder des Air Vac Cleanout Systems, das Zeit- und Arbeitsaufwand sowie Querverunreinigung beim Chargen- oder Produktwechsel vermindert. Aufgrund der Produktionseinsparungen macht sich das System schnell bezahlt.

Universal Industries Ausrüstung bedient eine Vielzahl von Märkten und Industrien, darunter die Saatgut-, Nuss-, Getreide-, Düngemittel-, Stahl-, Fertigungs-, Munitions-, Gewürz-, Haustier- und Viehfutterindustrie, die chemische und pharmazeutische Industrie sowie die Metallpulver- und Recyclingindustrie uvm.



A Universal Industries fabrica equipamentos para manuseio de materiais em granel, em baixas velocidades, especializados para o manuseio de produtos frágeis, abrasivos e/ou facilmente fluidizados. Oferecemos três opções de elevadores (photos marked *, **, ***) o máximo em manuseio brando de materiais. Há muitos anos que o setor de sementes usa como padrão o sistema EASY DUMP™ (*). A maioria dos modelos é fornecida em aço-carbono, inoxidável e galvanizado.

A Universal é inovadora, tendo lançado o Sistema Air Vac Cleanout, que reduz o tempo, mão de obra e contaminação cruzada entre lotes de diversos produtos diferentes. A unidade será paga rapidamente só com a economia gerada na sua produção.

Os equipamentos da Universal Industries atendem uma vasta gama de mercados e setores, inclusive sementes, frutas secas, grãos, fertilizantes, forjaria, produtos industrializados, munições, produtos químicos, temperos, comidas para animais domésticos e rações, metais em pó, produtos farmacêuticos, reciclagem...e muito mais.



ユニバーサル・インダストリーズ社は、壊れやすい物、研磨作用のある物、および（または）流動化しやすい物を低速で取り扱う特殊バルク材取り扱い装置を製造しています。当社エレベーターには、究極の優しい取り扱いとして3つのチョイスがあります。（写真のマーク*、**、***の順に優しい取り扱いから最も優しい取り扱いになります。）EASY DUMP™(*)ラインは、長年にわたってアメリカの種子産業における標準となっています。ほとんどの型式には、カーボン、ステンレス、または亜鉛メッキ鋼のものがあります。

ユニバーサル社は、エアークリーンアウトシステムにおいて革新的な技術を有しており、多くの製品を交換して使用する際に時間と労力の節約ができ、また相互汚染が減少します。生産における節約で、当社ユニットのご使用は短期間で元が取れます。

ユニバーサル・インダストリーズ社の装置は、種子、ナッツ、穀物、肥料、鋳物、製造、軍需品、化学製品、スパイス、ペットおよび家畜の飼料、粉末金属、医薬品、リサイクルなど、非常に広範な市場と産業に役立っています。



Universal Industries fabrica equipos especiales para manejo de materiales a granel a bajas velocidades, ideales para productos que son frágiles, abrasivos, y/o fácilmente fluidizados. Para lo último en manejo suave de materiales, le ofrecemos tres opciones (fotografías marcadas *, **, ***) desde suave hasta super suave) en nuestros elevadores. La línea EASY DUMP™ (*) ha sido la norma de la industria de semillas estadounidense por muchos años. La mayoría de los modelos está disponible en aceros al carbono, inoxidable o galvanizado.

Universal es el innovador del sistema de limpieza Air Vac, que se caracteriza por ahorrar tiempo y mano de obra, además de reducir la contaminación cruzada durante los cambios de lotes o de productos. Los ahorros de producción amortizarán rápidamente al equipo.

El equipo de Universal Industries se encuentra en servicio en una vasta gama de mercados e industrias incluyendo las de semillas, nueces, granos, fertilizantes, fundiciones, manufactura, municiones, productos químicos, especias, alimentos para mascotas y ganado, metal en polvo, productos farmacéuticos, reciclaje... y mucho más.



Universal Industries fabrique des équipements spéciaux pour manipulation de matériaux en vrac, en utilisant des vitesses réduites pour manipuler les produits qui sont fragiles, abrasifs, et/ou facilement fluidisés. Pour ce qu'il se fait de mieux en manipulation douce, vous avez trois choix (photos repérées *, **, ***) pour le degré de douceur) dans nos élévateurs. La ligne EASY DUMP™ (*) a été le standard dans l'industrie américaine des grains pendant de nombreuses années. La plupart des modèles en acier sont disponibles au carbone, inoxydables ou galvanisés.

Universal est novateur avec son système de nettoyage Air Vac Cleanout, qui réduit la durée, la main d'œuvre et la contamination croisée quand vous déplacez des lots ou produits. Les économies réalisées en production paient rapidement l'investissement.

Les équipements Universal Industries desservent une gamme étendue de marchés et d'industries, comprenant graines et semences, granulés, fonderie, fabrication, munitions, produits chimiques, épices, aliments pour animaux de compagnie et bétail, métal fritté, produits pharmaceutiques, recyclage... et beaucoup d'autres.



Universal Industries produce attrezzature speciali per la movimentazione di materiale alla rinfusa che impiegano basse velocità, per il trasporto di prodotti fragili, abrasivi e/o facilmente fluidificabili. Per garantire un trasporto efficace e sicuro potete scegliere fra tre opzioni (foto contrassegnate con *, **, ***, in ordine crescente di sicurezza) dei nostri elevatori. La linea EASY DUMP™ (*) è stata per molti anni l'attrezzatura standard dell'industria delle sementi americana. La maggior parte dei modelli è disponibile in carbonio, acciaio inossidabile o acciaio zincato.

Universal Industries è l'azienda produttrice dell'innovativo Air Vac Cleanout System, che riduce tempi, fatica e rischi di contaminazione incrociata durante lo scambio di lotti o prodotti. Il risparmio in termini di produzione ammortizza rapidamente il costo dell'unità.

Le attrezzature Universal Industries trovano impiego in una vasta gamma di mercati e industrie, inclusi sementi, noci, grano, fertilizzante, fonderie, industrie manifatturiere, munizioni, sostanze chimiche, spezie, mangimi per animali, metalli in polvere, prodotti farmaceutici, impianti di riciclaggio...ed altro ancora.



环球工业制造专业性散料装卸设备，利用低速装卸那些易碎、易磨损、和或易液化的产品。为了最大限度地减缓装卸，在我们的装卸机中有三种选择（见标有*、**、***的照片，从轻柔至最轻）。EASY DUMP™(*)易卸机多年来已经成为美国种子业的行业标准。大多数型号都有，如碳钢、不锈钢或镀锌钢等。

环球公司发明了真空气动式清理系统，所以在交换地点或产品时使用此系统能节省时间，减少劳力和交叉污染，所带来的生产节约可以很快地补偿购买设备的费用。

环球工业的设备服务于庞大的行业市场，包括种子、坚果、粮食、肥料、铸造、制造、军需品、化学品、香料、宠物以及家畜饲料、金属粉末、医药、回收再生及其他许多行业部门……等等。



5800 Nordic Drive • PO Box 308 • Cedar Falls, IA 50613-0308
Phone: 319.277.7501 • Toll Free: 800.553.4446 • Fax: 319.277.2318
Website: www.universalindustries.com
email: sales@universalindustries.com

©2001 Printed in USA



**Moving
your product
in the right direction!**

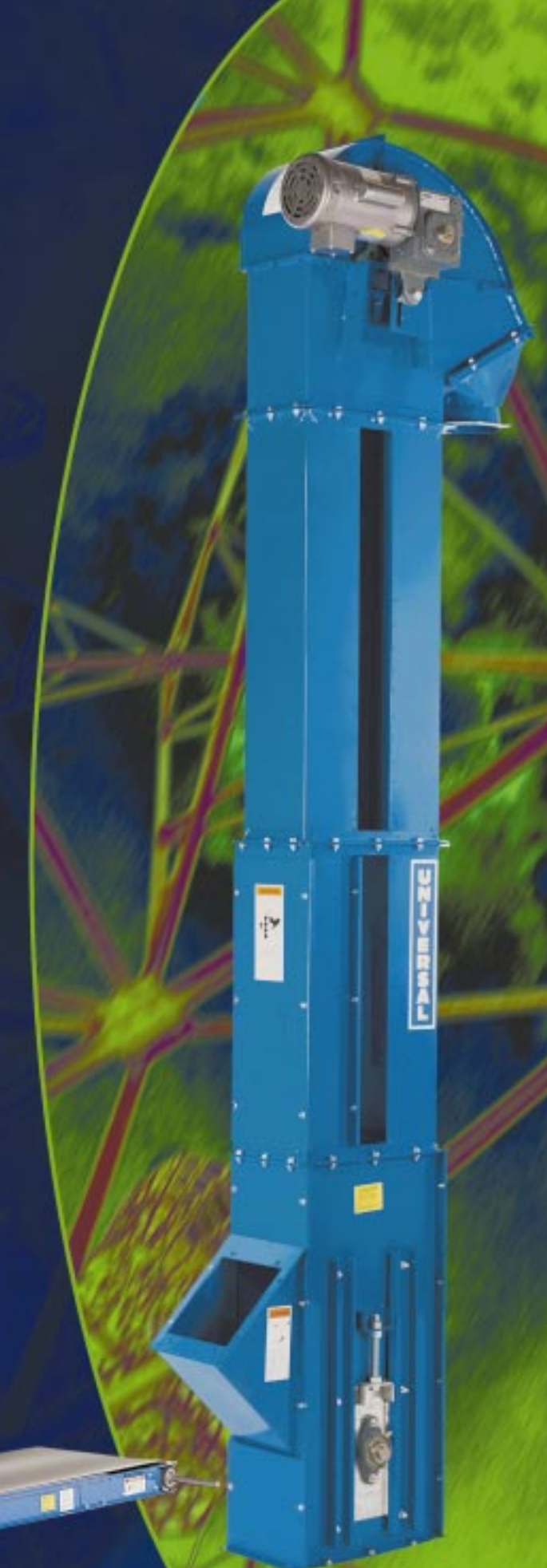

* Exclusive EASY DUMP™

** Gentler handling

*** Gentlest handling

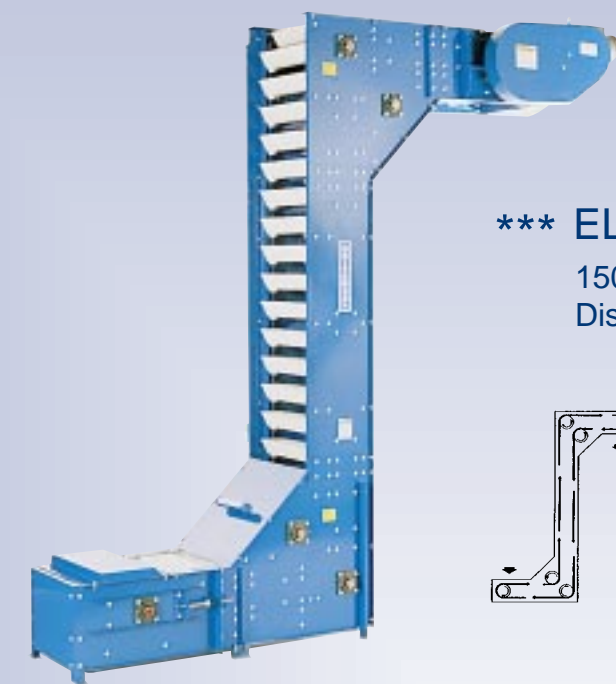

*** EL-CON

150-4000ft³/h (4.2-112m³/h)
Discharge: vertical, 50' (15.3m)
horizontal, 100' (50.3m)

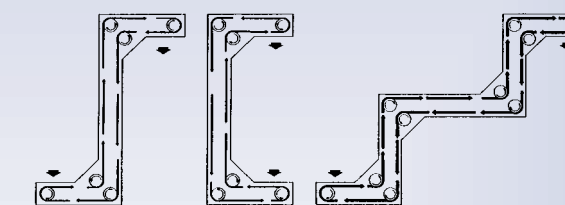

**MOST MODELS AVAILABLE IN
CARBON, STAINLESS OR
GALVANIZED STEEL**

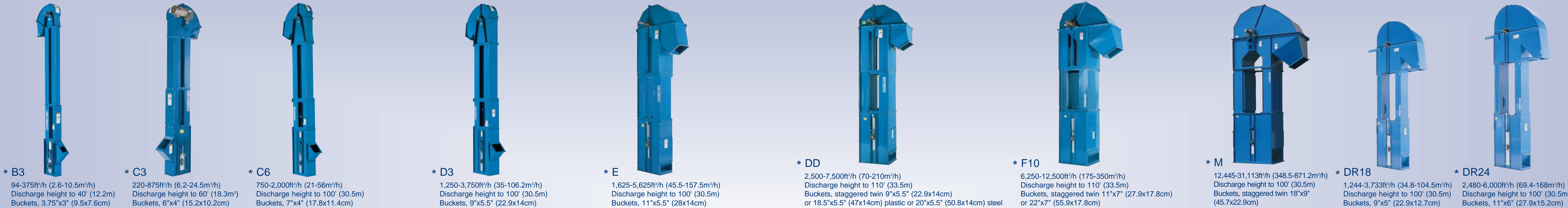

<p>* B3 94-375ft³/h (2.6-10.5m³/h) Discharge height to 40' (12.2m) Buckets, 3.75"x3" (9.5x7.6cm)</p>	<p>* C3 220-875ft³/h (6.2-24.5m³/h) Discharge height to 60' (18.3m) Buckets, 6"x4" (15.2x10.2cm)</p>	<p>* C6 750-2,000ft³/h (21-56m³/h) Discharge height to 100' (30.5m) Buckets, 7"x4" (17.8x11.4cm)</p>	<p>* D3 1,250-3,750ft³/h (35-106.2m³/h) Discharge height to 100' (30.5m) Buckets, 9"x5.5" (22.9x14cm)</p>	<p>* E 1,625-5,625ft³/h (45.5-157.5m³/h) Discharge height to 100' (30.5m) Buckets, 11"x5.5" (28x14cm)</p>	<p>* DD 2,500-7,500ft³/h (70-210m³/h) Discharge height to 110' (33.5m) Buckets, staggered twin 9"x5.5" (22.9x14cm) or 18.5"x5.5" (47x14cm) plastic or 20"x5.5" (50.8x14cm) steel</p>	<p>* F10 6,250-12,500ft³/h (175-350m³/h) Discharge height to 110' (33.5m) Buckets, staggered twin 11"x7" (27.9x17.8cm) or 22"x7" (55.9x17.8cm)</p>	<p>* M 12,445-31,113ft³/h (348.5-871.2m³/h) Discharge height to 100' (30.5m) Buckets, staggered twin 18"x9" (45.7x22.9cm)</p>	<p>* DR18 1,244-3,733ft³/h (34.8-104.5m³/h) Discharge height to 100' (30.5m) Buckets, 9"x5" (22.9x12.7cm)</p>	<p>* DR24 2,480-6,000ft³/h (69.4-168m³/h) Discharge height to 100' (30.5m) Buckets, 11"x6" (27.9x15.2cm)</p>
---	---	---	--	--	---	---	--	--	---

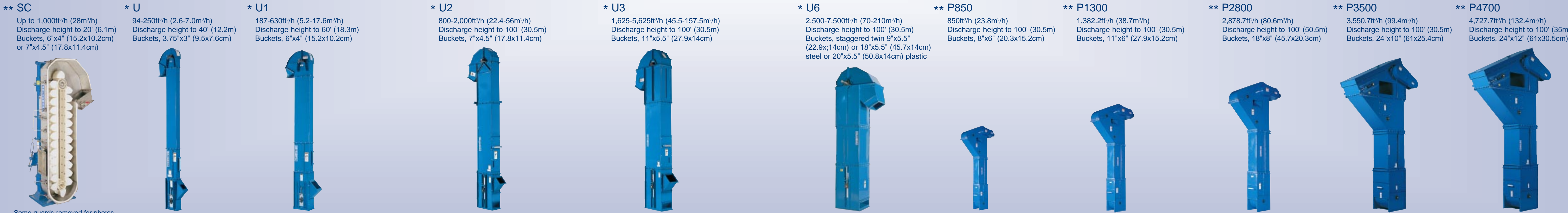

<p>** SC Up to 1,000ft³/h (28m³/h) Discharge height to 20' (6.1m) Buckets, 6"x4" (15.2x10.2cm) or 7"x4.5" (17.8x11.4cm)</p>	<p>* U 94-250ft³/h (2.6-7.0m³/h) Discharge height to 40' (12.2m) Buckets, 3.75"x3" (9.5x7.6cm)</p>	<p>* U1 187-630ft³/h (5.2-17.6m³/h) Discharge height to 60' (18.3m) Buckets, 6"x4" (15.2x10.2cm)</p>	<p>* U2 800-2,000ft³/h (22.4-56m³/h) Discharge height to 100' (30.5m) Buckets, 7"x4.5" (17.8x11.4cm)</p>	<p>* U3 1,625-5,625ft³/h (45.5-157.5m³/h) Discharge height to 100' (30.5m) Buckets, 11"x5.5" (27.9x14cm)</p>	<p>* U6 2,500-7,500ft³/h (70-210m³/h) Discharge height to 100' (30.5m) Buckets, staggered twin 9"x5.5" (22.9x14cm) or 18"x5.5" (45.7x14cm) steel or 20"x5.5" (50.8x14cm) plastic</p>	<p>** P850 850ft³/h (23.8m³/h) Discharge height to 100' (30.5m) Buckets, 8"x6" (20.3x15.2cm)</p>	<p>** P1300 1,382.2ft³/h (38.7m³/h) Discharge height to 100' (30.5m) Buckets, 11"x6" (27.9x15.2cm)</p>	<p>** P2800 2,878.7ft³/h (80.6m³/h) Discharge height to 100' (30.5m) Buckets, 18"x8" (45.7x20.3cm)</p>	<p>** P3500 3,550.7ft³/h (99.4m³/h) Discharge height to 100' (30.5m) Buckets, 24"x10" (61x25.4cm)</p>	<p>** P4700 4,727.7ft³/h (132.4m³/h) Discharge height to 100' (30.5m) Buckets, 24"x12" (61x30.5cm)</p>
--	---	---	---	---	---	---	---	---	--	---

Some guards removed for photos