



B3

BUCKET ELEVATORS

up to 375 ft³/h
(10 m³/h)
/300 BPH

**GENTLE, EFFICIENT
HANDLING FOR
SEEDS AND OTHER
BULK MATERIALS**



**EXCLUSIVE “EASY DUMP™” DESIGN
(B3-75ED only)**

SPECIFICATIONS

Model	B3-75ED	B3-200	B3-300
Capacity - Free Flowing Material @ 75% Bucket fill	75 BPH 94 ft ³ /h 2.7 m ³ /h	200 BPH 250 ft ³ /h 7.0 m ³ /h	300 BPH 375 ft ³ /h 10 m ³ /h
Short TPH @ 50lbs/ft ³	2.25	6.25	9.25
Short TPH @ 75lbs/ft ³	3.5	9.3	14.0
Belt Speed	82-98 fpm	185 fpm	270 fpm
Headshaft RPM	70-90 rpm	170 rpm	250 rpm
Bucket Spacing	3-1/4"	3-1/4"	3-1/4"
Head Casing	14 gauge		
Headshaft Dia.	1-3/16" diameter		
Headshaft Bearing	Ball Bearing Pillow Block		
Head Pulley	4-1/4" diameter with vulcanized rubber lagging		
Buckets	3-3/4" x 3" plastic or 18 gauge steel		
Belting	4" wide PVC, rubber optional		
Legging	16 gauge twin box columns		
Boot Casing	12 gauge		
Bootshaft	1-3/16" diameter		
Bootshaft Bearing	1-3/16" Two bolt flange		
Boot Pulley	Slatted self cleaning style		
Construction	Carbon, galvanized or 304 stainless steel		
Drive Package	Optional		
Motor	Optional		

**THE TRADITION OF
EXCELLENCE CONTINUES!**

(Guards removed for photos only)

MODEL B3

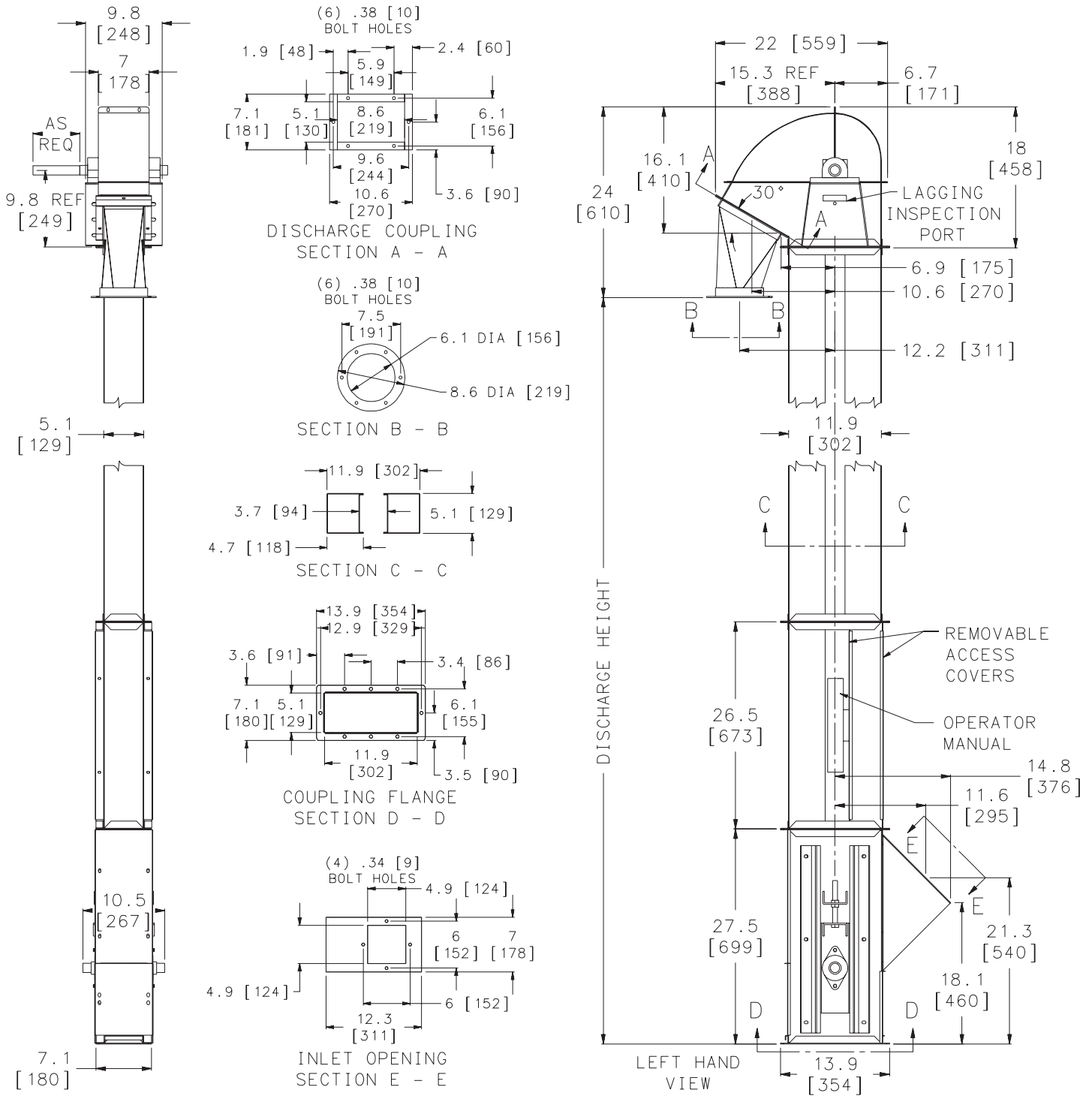

NOTE: Unit application, location and specifications determine the type, quantity and/or placement of electrical, electrical safety or other safety controls required. Whether these controls are supplied by Universal Industries or another supplier, all OSHA safety and health standards, the National Electrical Code and local codes must be met and followed. Because we constantly strive to provide the finest material handling equipment, establishing industry standards, specifications must remain subject to change without notice.

