



**MPK**

**CONVEYORS**

*up to 4,500 CFH @  
267 FPM*

**HANDLES EVEN CORROSIVE,  
ABRASIVE, MATERIALS  
WITH GREAT EASE**

**BIG CAPACITY, WITH LOW BELT SPEED TO MINIMIZE SPLASH**



**SPECIFICATIONS**

Model	MPK 12	MPK 16	MPK 24
Belt Width	12"	16"	24"
Capacity @ 267 FPM	1,700 ft <sup>3</sup> /h 48.1 m <sup>3</sup> /h	2,500 ft <sup>3</sup> /h 70.8 m <sup>3</sup> /h	4,500 ft <sup>3</sup> /h 127.4 m <sup>3</sup> /h
Belt Speeds	25-267 FPM*		
Bearings	Sealed industrial ball bearings		
Head Pulley	6 1/4" dia. with vulcanized rubber lagging		
Headshaft	1 7/16" and 1 15/16" dia.		
Tail Pulley	6" dia. Self Cleaning		
Belt Take-up	8"		
Length (minimum)	2' center to center		
Length (maximum)	70' center to center*		
Depth of Conveyor	7 1/8"		
Depth of Trough	1 1/2"		
Frame C on struction	11 Ga. formed channel		
Trough construction	14 Ga.		
Drive (optional)	Shaft mounted reducer or gear reducer w/ roller chain & sprockets		
Trough Formula	Shaft Centers minus 21"		
Belt Formula	2x shaft centers plus 21" (under 30') 2x shaft centers plus 27" (over 30')		

**THE TRADITION  
OF  
EXCELLENCE  
CONTINUES!**

\*For speeds or lengths other than listed, please consult sales department.  
(Guards removed for photos only)

# MODEL MPK

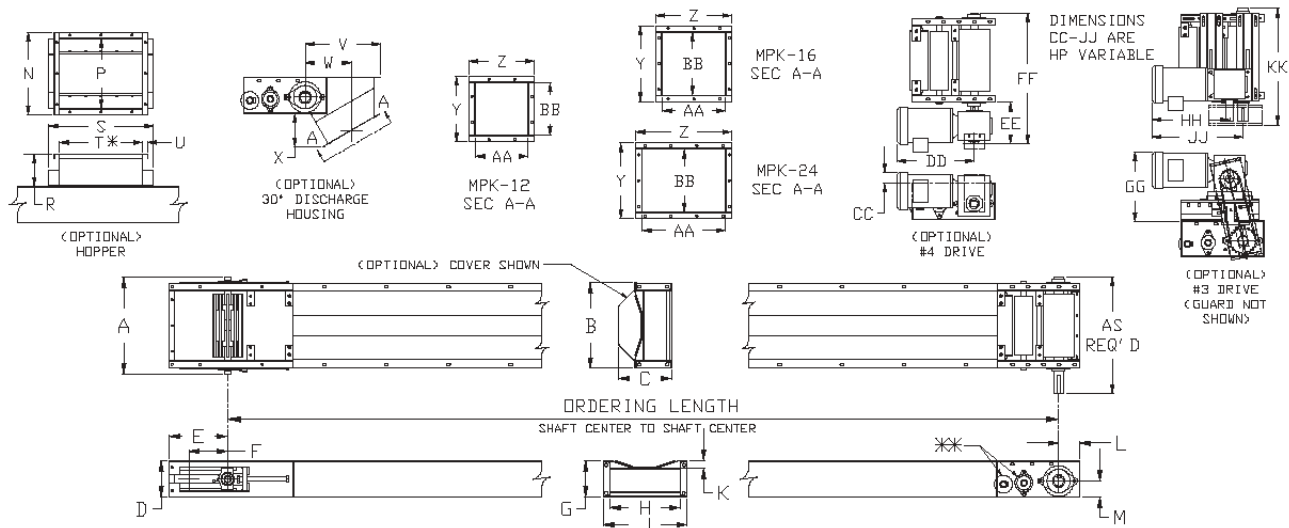

MODEL	DIM	A	B	C	D	E	F	G	H	J	K	L	M	N
MPK-12	in	18.6	16.5	10.2	7	11.3	7.5	7.1	13.5	16.3	1.5	4.1	3.1	15.9
	mm	473	419	260	178	287	191	180	343	413	38	103	79	404
MPK-16	in	22.6	20.5	10.2	7	11.3	7.5	7.1	17.5	20.3	1.5	4.1	3.1	19.8
	mm	574	521	260	178	287	191	180	443	514	38	103	79	502
MPK-24	in	30.6	28.5	10.2	7	11.3	7.5	7.1	25.5	28.3	1.5	4.1	3.1	27.8
	mm	777	724	260	178	287	191	180	648	718	38	103	79	705

MODEL	DIM	P	R	S	T	U	V	W	X	Y	Z	AA	BB	KK
MPK-12	in	13.5	6.2	20.2	16	1.1	14.6	8.9	6.5	12.6	12.6	10.1	10.1	22.3
	mm	342	156	512	406	28	370	226	165	321	321	257	257	566
MPK-16	in	17.4	6.2	20.2	16	1.1	11.8	5.3	6.1	14.6	14.6	12.1	12.1	26.4
	mm	443	156	512	406	28	298	135	156	371	371	307	307	671
MPK-24	in	25.4	6.2	20.2	16	1.1	11.8	5.3	6.6	14.6	18.5	16	12.1	34.4
	mm	646	156	512	406	28	298	135	168	371	470	406	308	874

\* 3, 4, 5' LENGTHS AVAILABLE (S WILL VARY ACCORDINGLY)

MODEL MPK 12/16/24 CONVEYOR DIMENSIONAL PAGE	
REF.	DRAWING NO. 1500D
COPYRIGHT UNIVERSAL INDUSTRIES 1996	

\*\* SNUB & RETURN PULLEY STANDARD AT 30' & OVER

NOTE: Unit application, location and specifications determine the type, quantity and/or placement of electrical, electrical safety or other safety controls required. Whether these controls are supplied by Universal Industries or another supplier, all OSHA safety and health standards, the National Electrical Code and local codes must be met and followed. Because we constantly strive to provide the finest material handling equipment, establishing industry standards, specifications must remain subject to change without notice.

