



**MPKUT**

**CONVEYORS**

*up to 4,930 CFH @  
267 FPM*

**HANDLES EVEN CORROSIVE,  
ABRASIVE, MATERIALS  
WITH GREAT EASE  
U TROUGH DESIGN**



## SPECIFICATIONS

Model	MPKUT 12	MPKUT 16	MPKUT 24
Belt Width	12"	16"	24"
Capacity @ 267 FPM	1,900 ft <sup>3</sup> /h 53.8 m <sup>3</sup> /h	2,780 ft <sup>3</sup> /h 78.7 m <sup>3</sup> /h	4,930 ft <sup>3</sup> /h 139.6 m <sup>3</sup> /h
Belt Speeds	25-267 FPM*		
Bearings	Sealed industrial ball bearings		
Head Pulley	6 1/4" dia. with vulcanized rubber lagging		
Headshaft	1 7/16" and 1 15/16" dia.		
Tail Pulley	6" dia. Self Cleaning		
Belt Take-up	8"		
Length (minimum)	2' center to center		
Length (maximum)	70' center to center*		
Depth of Conveyor	7 1/8"		
Depth of Trough	1 1/2"		
Frame Construction	11 Ga. formed channel		
Trough Construction	14 Ga.		
Drive (optional)	Shaft mounted reducer or gear reducer w/ roller chain & sprockets		
Trough Formula	Shaft Centers minus 21"		
Belt Formula	2x shaft centers plus 21" (under 30') 2x shaft centers plus 27" (over 30')		

\*For speeds or lengths other than listed, please consult sales department.  
(Guards removed for photos only)

**THE TRADITION  
OF  
EXCELLENCE  
CONTINUES!**

# MODEL MPKUT

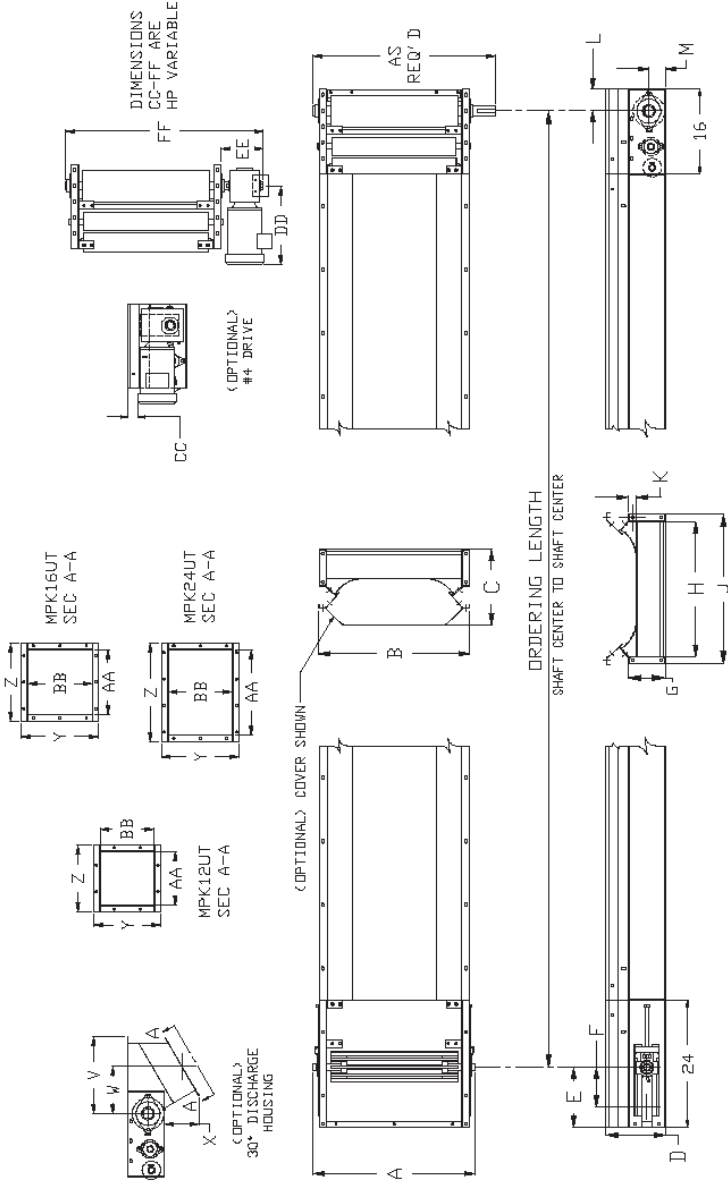

MODEL	DIM	A	B	C	D	E	F	G	H	J	K	L	M	N
MPK12UT	in	18.6	16.5	14.3	11.1	11.3	7.5	7.1	13.5	16.3	1.5	4.1	3.1	15.9
	mm	473	419	362	285	287	191	180	343	413	38	103	79	404
MPK16UT	in	22.6	20.5	14.3	11.1	11.3	7.5	7.1	17.5	20.3	1.5	4.1	3.1	19.8
	mm	574	521	362	285	287	191	180	445	514	38	103	79	502
MPK24UT	in	30.6	28.5	14.3	11.1	11.3	7.5	7.1	25.5	28.3	1.5	4.1	3.1	27.8
	mm	777	724	362	285	287	191	180	648	718	38	103	79	705

MODEL	DIM	P	R	S	T	U	V	W	X	Y	Z	AA	BB	KK
MPK12UT	in	13.5	6.2	20.2	16	1.1	14.6	8.9	6.5	12.6	12.6	10.1	10.1	22.3
	mm	342	156	512	406	28	370	226	165	321	321	257	257	566
MPK16UT	in	17.4	6.2	20.2	16	1.1	11.8	5.3	6.1	14.6	14.6	12.1	12.1	26.4
	mm	443	156	512	406	28	298	135	156	371	371	307	307	671
MPK24UT	in	25.4	6.2	20.2	16	1.1	11.8	5.3	6.6	14.6	18.5	16	12.1	34.4
	mm	645	156	512	406	28	298	135	169	371	470	405	308	874

\* INLET LENGTHS and QUANTITY AVAILABLE per REQUIREMENTS

MODEL MPK-UT CONVEYOR DIMENSIONAL PAGE
REF. DRAWING NO. 15300
COPYRIGHT UNIVERSAL INDUSTRIES, Inc. 1999

NOTE: Unit application, location and specifications determine the type, quantity and/or placement of electrical, electrical safety or other safety controls required. Whether these controls are supplied by Universal Industries or another supplier, all OSHA safety and health standards, the National Electrical Code and local codes must be met and followed. Because we constantly strive to provide the finest material handling equipment, establishing industry standards, specifications must remain



**Universal Industries**  
 5800 Nordic Drive • PO Box 308 • Cedar Falls, IA 50613-0308  
 1-800-553-4446 • 319-277-7501 • FAX 319-277-2318  
 www.universalindustries.com • sales@universalindustries.com  
 Printed in U.S.A. © Copyright 1996