



**DESIGNED TO HANDLE
CORROSIVE, ABRASIVE
AND OTHER HOSTILE
MATERIALS**

U

**BUCKET
ELEVATORS**

*up to 250 CFH
(7 CMH)
/9.4 TPH*



**EXCLUSIVE “EASY DUMP™” DESIGN
(U-94ED only)**

SPECIFICATIONS

Model	U-94ED	U-250
Capacity - Free Flowing Material @ 75% Bucket fill	94 CFH 2.63 CMH	250 CFH 7.0 CMH
Short TPH @ 50 lbs. ft ³	2.25 TPH	6.25 TPH
Short TPH @ 75 lbs. ft ³	3.5 TPH	9.4 TPH
Belt/Chain Speed	82-98 FPM	185 FPM
Headshaft RPM	70-90 RPM	170 RPM
Bucket Spacing	3 1/4"	3 1/4"
Head Casing	14 gauge	
Headshaft Dia.	0 3/16" diameter	
Headshaft Bearing	Roller bearing pillow block	
Head Pulley	4 1/4" diameter crown face with vulcanized rubber lagging	
Buckets	3 3/4" x 3" plastic or 18 gauge steel	
Belting	4" wide PVC, rubber optional	
Legging	14 gauge single leg w/angle iron corners	
Boot Casing	12 gauge	
Bootshaft	1 3/16" diameter	
Bootshaft Bearing	Ball bearing 2 bolt flange	
Boot Pulley	Slatted self cleaning style	
Construction	Carbon or 304 stainless steel	
Drive Package	Optional	
Motor	Optional	

**THE TRADITION OF
EXCELLENCE CONTINUES!**

(Guards removed for photos only)

MODEL U

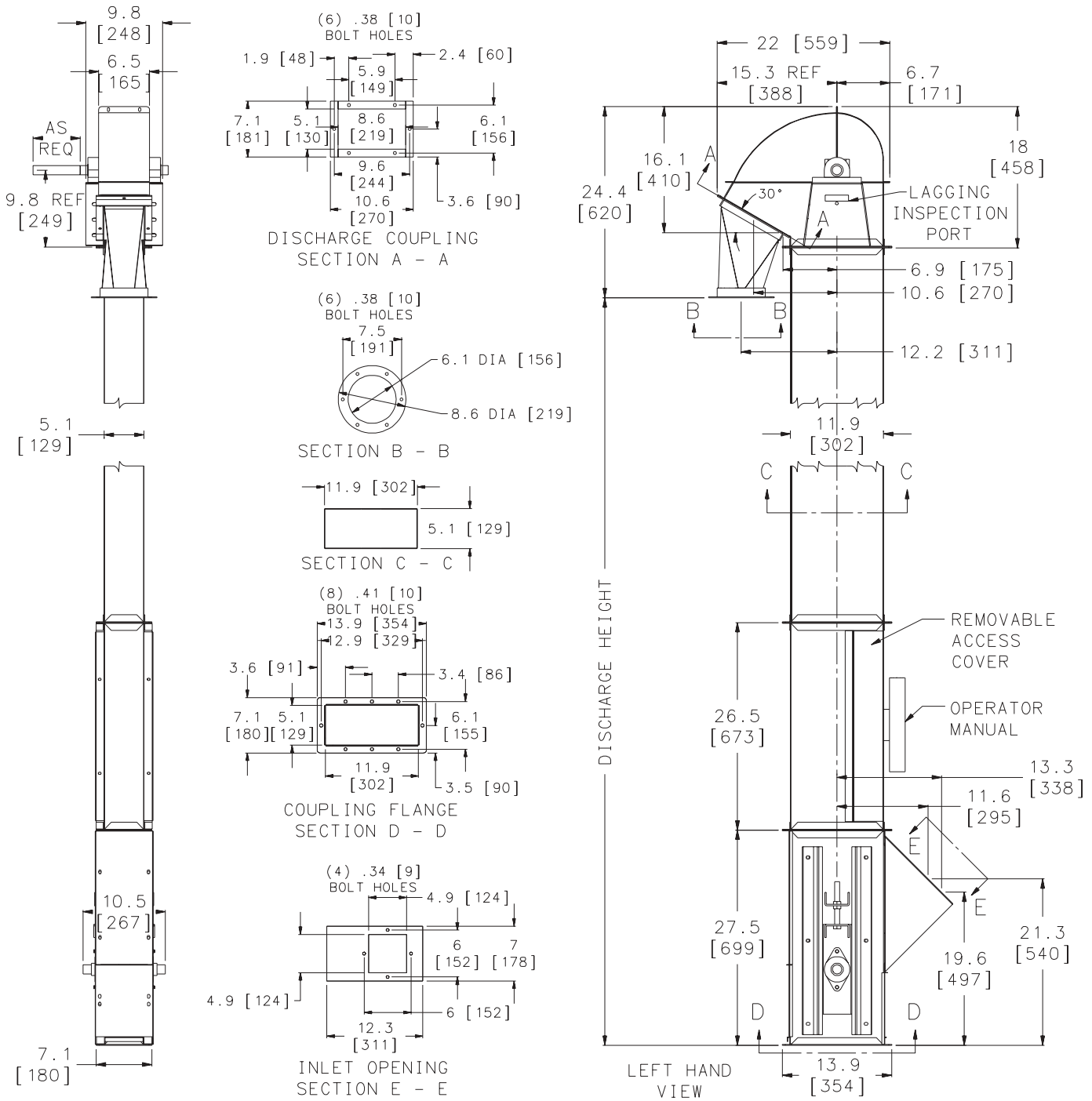

NOTE: Unit application, location and specifications determine the type, quantity and/or placement of electrical, electrical safety or other safety controls required. Whether these controls are supplied by Universal Industries or another supplier, all OSHA safety and health standards, the National Electrical Code and local codes must be met and followed. Because we constantly strive to provide the finest material handling equipment, establishing industry standards, specifications must remain subject to change without notice.

