



**Universal  
Industries**  
Universal Industries, Inc.



# B3

## Manual

Safety, Installation, Maintenance,  
Operation & Parts

**Part # 41941**

Model: \_\_\_\_\_

S.N.: \_\_\_\_\_

Date: \_\_\_\_\_

For Parts or Service Contact:

**Universal Industries, Inc.**

5800 Nordic Drive • P.O. Box 308 • Cedar Falls, IA 50613-0308  
Phone: (319) 277-7501 • Fax: (319) 277-2318



## SECTION 1

## TERMS AND CONDITIONS OF SALE

### TERMS AND CONDITIONS OF SALE

1. **TERMS OF PAYMENT:** Buyer agrees to pay the purchase price shown on the acknowledged Sales Order in accordance with the terms of payment stated on the Sales Order. Amounts not paid when due shall accrue interest at the rate of 1.5% per month from the due date. For all sales on open account, the full purchase price shall be due 30 days from the date of the Invoice. However, Seller reserves the right to require down payment and/or progress payments, which shall be specified on the Sales Order. Unless otherwise specified, all sales are exclusive of freight, taxes, and other amounts due third parties. Discounts for early payment shall be as stated on the Invoice. Discounts shall not apply to the amount of any freight, taxes of other sums due any third party. Terms begin on the date of the Invoice. Seller shall establish the credit terms available to Buyer based on a current credit application and any other information available to Seller. At any time, Seller may limit or cancel the amount or time of credit extended to Buyer, in the sole opinion of Seller. Buyer shall pay in cash before delivery (C.O.D) for any order or part of an order in excess of the approved credit terms of Buyer. In the event Buyer fails to pay in advance any amount demanded by Seller, Seller shall have the right, in addition to any other remedies available, to cancel the contract or sell all or any part of the undelivered goods without notice at public or private sale, holding Buyer responsible for any deficiency.

2. **SECURITY INTEREST:** Seller reserves and Buyer hereby grants to Seller a security interest in the goods shipped under this agreement and the proceeds derived from their sale of whatever nature, whether in cash, note or account. This security interest shall continue until the full purchase price and any related expenses and/or charges due in connection with the Sales Order are paid in full. Notes shall not be considered as payment buy merely as evidence of indebtedness. Seller shall be entitled to all the rights of a secured party under Iowa law. Buyer agrees to execute any documents required to perfect or confirm this security interest.

3. **TITLE/RISK OF LOSS:** Title to all goods priced at shipping point shall pass to Buyer upon delivery at such shipping point. All risk of loss shall be Buyer's from the time of shipment. Seller's responsibility for any loss or damage to the goods ceases at the time delivery is made to the carrier. Buyer shall be solely responsible for making any claim(s) against the carrier for any loss or damage.

4. **EXPORT ORDERS:** Prices for export-crating charges can be obtained by contacting the Sales Department for quotations and orders.

5. **PRICE CHANGES:** The prices listed may be changed by Seller without notice in order to reflect Seller's prices at time of shipment and any increase in transportation, labor or other costs. If a delivered price has been quoted, any charges at destination for spotting, switching, handling, storage, and other accessorial services and demurrage shall be borne by Buyer. Seller reserves the right to correct any obvious errors or mistakes in specifications or prices.

6. **WHEN ORDERING:** Please specify name of item, catalog part number, as well as other information when this is applicable to insure prompt handling of the order.

7. **MINIMUM BILLING:** \$50.00 Net, exclusive of transportation charges.

8. **DELIVERIES:** Any delivery schedule indicated is based on Seller's present estimate of the time required to ship after receipt of Buyer's order. In the event of any delay in Seller's performance due in whole or in part to any cause beyond Seller's reasonable control, Seller shall have such additional time for its performance as may be reasonably necessary under the circumstance.

9. **MANUALS:** Seller will furnish one combined safety, installation, operation, maintenance, and parts manual. Extra manuals will be sent on request.

10. **SHIPMENT:** Shipment may be by carrier or other means selected by Seller. All units are shipped-knocked down. If shipment is delayed by Buyer, date of readiness for shipment shall be deemed to be date of shipment for payment purposes. If manufacture is delayed by Buyer, a payment shall be made based on purchase price and percentage of completion, balance payable in accordance with the terms as stated. Equipment held for Buyer shall be at the risk and expense of Buyer.

11. **LIMITED WARRANTY:** Seller warrants that the components and parts that it manufactures for its machines and equipment will be free from defects in material or workmanship for a period of one (1) year from the date of shipment by Seller. Seller does not warrant any component or part not manufactured by Seller. If, during the one year warranty period, Buyer discovers a defect in material or workmanship of a covered component, Buyer shall promptly (and in no event later than thirteen (13) months after the date of shipment by Seller) notify Seller in writing of such defect. Within a reasonable time of receiving such notification, Seller will furnish a replacement component or part. Buyer shall be responsible for all expenses attendant to the shipment and installation of the replacement component or part. Buyer also shall be responsible for returning the defective component or part to Seller if request by Seller to do so. **THE FOREGOING WARRANTY IS IN LIEU OF ALL OTHER WARRANTIES, EXPRESSED OR IMPLIED, SELLER DISCLAIMS THE IMPLIED WARRANTY OR MERCHANTABILITY AND ANY IMPLIED WARRANTY OF FITNESS FOR A PARTICULAR PURPOSE.**

**SELLER SPECIFICALLY DOES NOT WARRANT PARTS AND COMPONENTS PURCHASED BY SELLER FROM THIRD PARTY SUPPLIERS, INCLUDING, BUT NOT LIMITED TO, SUCH PARTS AND COMPONENTS AS MOTORS, BEARINGS, REDUCERS, AND SWITCHES. BUYER SHALL BE LIMITED IN RECOURSE FOR SUCH COMPONENTS AND PARTS TO THE TERMS OF THE WARRANTY OF THAT PARTICULAR MANUFACTURER.**

12. **LIMITATION OF REMEDIES AND DAMAGES:** Buyer's primary remedy for breach of warranty is the provision of a replacement component or part, as stated above. If Seller is unable to provide a replacement component or part, Buyer's alternate remedy shall be refund of Buyer's purchase price. These remedies are Buyer's sole and exclusive remedies for breach of warranty. In no event shall Seller be liable under any theory of liability for (i) damages in excess of Buyer's purchase price or (ii) any special, incidental or consequential damages.

13. **TIME TO BRING SUIT:** Buyer shall bring any action relating to the goods sold by Seller pursuant to his Sales Order or Invoice, including any action for breach of contract or breach of warranty, not later than two (2) years after the date of shipment by Seller. Buyer agrees that any action brought after such date shall be barred as being untimely.

14. **PLACE OF BRINGING SUIT:** Any action relating to the goods sold by Seller pursuant to this Sales Order or Invoice shall be brought in the Iowa District Court in and for Black Hawk County, Iowa.

## SECTION 1

15. **TOLERANCES AND VARIATIONS:** All goods shall be subject to tolerances and variations consistent with usual trade practices regarding dimension, straightness, section, composition and mechanical properties and normal variations in surface and internal conditions and quality and shall also be subject to deviations from tolerances and variations consistent with practical testing and inspection methods.

16. **RETURNS:** Returns are not accepted unless Seller is first notified of the reason for the return, and has granted permission for the return to be made. A return authorization tag will be issued on agreed-to returns. Credit for permitted returns will not exceed the price charged when shipment was made, or the market price at the time the return was received. 20% handling charge will be made on all returned goods. In case of damaged goods, the charge will rise accordingly. When the cause for return is due to incorrect shipment by Seller, there will be no restocking or freight charge. Any merchandise that is to be returned must be received with a return authorization tag attached and freight charges-Prepaid. Any returns authorized by Seller are conditioned upon the goods being returned in condition for resale.

17. **COPYRIGHT:** No reproduction either in whole or in part may be made from Seller's catalog, drawings, sketched, etc., without written permission from Seller's Sales Department.

18. **BACK ORDERS:** Seller will attempt to ship all orders complete; however, in the event of back orders, the orders will be shipped with freight charges, collect or prepaid, at Seller's option only.

19. **SHORTAGES:** Claims for shipping shortages concealed or otherwise, will not be allowed by Seller, unless reported within 15 days after date of shipment by Seller.

20. **PRODUCT CHANGES:** Seller reserves the right to change, without notice, the design or any modular, "standardized" components represented in Seller's catalog.

21. **TOOLS, DIES AND FIXTURES:** Unless otherwise expressly provided herein, any tools, dies, or fixtures which may be developed for Seller in the production of the goods covered hereby shall be owned by Seller, as Seller may elect, even though Buyer is charged in whole or in part for the cost of such tools, dies and fixtures.

22. **PATENT INFRINGEMENT:** If any of the goods are to be furnished to Buyer's specification, Buyer agrees to indemnify Seller and Seller's successors and assigns, against all liabilities and expenses resulting from any claim of infringement of any patent in connection with the production of such goods.

23. **SPECIAL DRAWING OR DATE REQUIREMENTS:** Seller will provide, upon request, an 8 ½ x 11 copy of any line drawing shown in the catalog without charge. Seller reserves the right to reject any request and/or assess a charge for any other drawing.

24. **CANCELLATION:** Except as otherwise provided in Paragraph 1, order may be cancelled or modified only by written agreement between the parties. On specially ordered or fabricated equipment, no cancellation will be allowed. Buyer's insistence upon cancelling or suspending fabrication or shipment, or Buyer's failure to furnish specifications when required, may be treated by Seller as a breach of contract by Buyer, and Seller may cancel any unshipped balance without prejudice to any other remedies Seller may have.

## TERMS AND CONDITIONS OF SALE

25. **TAXES:** All applicable federal, state or local sales, use, occupational or excise taxes are the responsibility of the Buyer and shall be in addition to the price or prices stated unless otherwise specifically stated. Seller shall have the right to Invoice separately any such tax as may be imposed at a later time. Applicable tax exemption certificates must accompany any order to which the same applies.

26. **MODIFICATIONS OF ALTERATIONS TO EQUIPMENT:** Seller shall not be liable for any product that is modified or altered by Buyer or its assignee or successor regardless of whether Seller knows or is aware of such modification or alteration.

27. **EQUIPMENT OPERATION:** Buyer agrees to require its employees to read and be familiar with the safety instructions and the operation and maintenance portion of the manual before operating this equipment. Buyer agrees to require its employees to use all safety devices and guards on the equipment and to use safe operating procedures. Buyer agrees to not remove or modify any such equipment, switch, device, guard or warning sign. If Buyer, or its employees, fail to strictly observe all of these obligations, Buyer agrees to indemnify and save Seller harmless from any liability or obligation incurred by Seller to persons injured directly or indirectly by the operation of the equipment.

28. **RESALE, TRANSFER, OR LEASE OF EQUIPMENT TO OTHERS:** Buyer agrees to the continuing obligation to notify Seller of the resale, transfer or lease of the equipment to third parties, stating the name and address of the new owner or transferee and the location of the equipment.

29. **REPORTING PERSONAL INJURIES OR PROPERTY DAMAGE:** The Buyer or user agrees to notify Seller within 30 days of any accident or occurrence involving Seller's machinery or equipment resulting in personal injury or property damage, and shall cooperate fully with Seller in investigating and determining the cause of such accident or occurrence. In the event that the Buyer or user fails to give such notice to Seller and so cooperate, the Buyer or user agrees to indemnify and save Seller harmless from all loss or damage arising from such accident or occurrence.

30. **ASSIGNABILITY:** Any contract for sale and purchase of machinery and equipment cannot be assigned except with the written consent of Seller.

31. **SUCCESSOR OWNERS AND USERS:** The terms and conditions hereof are binding on successor owners and users, who take by purchase, assignment, lease, or otherwise, the right to own, use or operate the equipment sold to the original Buyer, and said terms and conditions shall transfer with the equipment itself as an integral obligation of any successor to the original Buyer. The successor owner and user obligations and liabilities stated herein shall also apply if the original Buyer was a dealer and purchased the equipment from Seller for purposes of resale and transfer to third parties.

32. **ENTIRE AGREEMENT:** These Terms and Conditions of Sale constitute the entire agreement between the parties concerning any machinery or equipment sold and purchased. It shall not be modified or cancelled except by mutual agreement in writing signed by all parties.

33. **APPLICABLE LAW:** The laws of the state of Iowa shall govern and control the rights, duties, remedies, and obligations of Seller, Buyer, successors, user, and owner and Iowa law shall be used to interpret and construe all of the terms and conditions hereof.

UNIVERSAL INDUSTRIES, INC.  
PRODUCT SAFETY STATEMENT

To: Customers, Dealers, Owners, and Users

Universal Industries, Inc. strives to make its products safe. However, because of the wide variety of applications for its products, often Universal does not know how the equipment is being used and installed. Consequently, Universal cannot directly control the installation of its product to assure compliance with applicable safety codes and practices. Nevertheless, Universal has listed various safety codes, standards, and regulations in its Manuals to assist the owner-user in providing a safe installation.

Universal will continue its best efforts to design, build, and market a safe product, and will continue to advocate and urge a safe installation of that product.

Universal requests your written suggestions as to how its product could be manufactured to improve its safety, convenience of use, function, repair, and maintenance. Written suggestions should be dated, signed, and mailed to:

Product Safety and Planning  
Universal Industries, Inc.  
P.O. Box 308  
Cedar Falls, Iowa 50613



This is a **safety alert symbol** and is used in this manual and on signs placed on the machine to call attention to specific safety precautions.

The following words are **signal words**. Signal words have specific meaning when used with this symbol.

## CAUTION

Denotes a general reminder of good safety practices or to direct attention to unsafe practices which, could result in personal injury if proper precautions are not taken.

## WARNING

Denotes specific potential hazard, which can result in injury or death if proper precautions are not taken.

## DANGER

Denotes the most serious specific potential hazard, which would result in high probability of death or irreparable injury if proper precautions are not taken.

All machines have inherent hazards such as moving parts, energy (electrical, mechanical or hydraulic), sharp edges and fumes or dust. Personnel must keep clear of moving machinery. Only authorized and trained persons are to be involved in the operation of this machine. **Any disregard for instructions and safety precautions can cause serious injury or death.**

Guards, disconnects, lock-outs and other features are provided or are available to improve operator safety.

This machine must not be altered in any manner or operated with any damaged, missing, or malfunctioning parts. If modification is deemed necessary to accomplish the user's requirements, write or FAX a description including a sketch or drawing to the Company with identification, condition and any previous modifications. The company may be able to help the customer avoid creating a hazardous situation. Careful attention must be given to adjacent machinery and accessible space for cleaning and inspection. Other factors should be planned for such as: product spillage, dust pollution, personnel space, interfacing of machines, automatic startup, and handling of hot materials.

THE FREQUENT USAGE OF ELEVATORS AND CONVEYORS TOGETHER WITH THE NECESSARY CONNECTION BETWEEN THEM MAKES IT ADVISABLE TO ADDRESS THE SAFETY CONSIDERATIONS OF BOTH UNITS EVEN THOUGH THE READER MIGHT BE DEALING ONLY WITH AN ELEVATOR OR ONLY A CONVEYOR.

 **WARNING****INSTRUCTIONS AND WARNING FOR USE OF COVER OR GRATE ON *OPEN SYSTEM* ELEVATORS**

The company recommends that for safety reasons its elevator and/or hopper be closed or covered during the time it is in operation.

The company cannot know all the applications of its elevators by its customers, but recognizes that there may be some applications where the material being elevated or conveyed requires that there be an *open system*. (Open system is when the hopper is exposed and open to view and to bodily parts during operation).

The purchaser and/or user is instructed and warned that the handling of certain materials may call for the use of an open system. Thus requiring the use of certain grates or guards to prevent persons from using or operating the unit and coming in contact with the moving parts, thereby sustaining serious bodily injuries or death.

When such an open system is to be operated, the purchaser or user is referred to ANSI or OSHA Regulations in Section 12 of this manual which may be applicable to the improved safety for the operator.

**SAFETY** **WARNING****FAILURE TO FOLLOW THESE INSTRUCTIONS COULD RESULT IN SEVERE INJURY OR DEATH****CONSTRUCTION OF WALKWAY OVER CONVEYOR AND/OR ELEVATOR INLET**

The Company assumes that personnel or the operator will not step on, across, or over the conveyor or elevator inlet while it is stopped or running. The Company also places a **Warning Sign** on the conveyor and elevator inlet to warn against such acts.

The user, however, may have a unique and particular usage that requires the operator of the conveyor or elevator to cross over the unit. Whether the conveyor or elevator is running or stopped, if such a usage is anticipated or necessary to accomplish the users' purpose, a permanent guarded walkway should first be constructed over and across the conveyor or elevator inlet in accordance with OSHA and other appropriate standards and regulations. Conveyors and elevator inlets should be crossed only at these designated points.

**FAILURE TO FOLLOW THESE INSTRUCTIONS COULD RESULT IN SEVERE INJURY OR DEATH**

Plan for and provide adequate lifting and moving equipment for safe unloading of heavy, bulky machine subassemblies.

Allow enough time for personnel to safely unload the machinery. Do not allow inclement weather or the pressure of installation schedules to unduly hurry the unloading and check-in process.

Immediately check goods received against the bill of lading and packing list, making note of those items that may have been back ordered.

Inspect boxes, crates and machinery for damage. Notify freight carrier immediately of missing pieces or damage claims. Open boxes and examine contents for completeness of order and/or damage. The buyer must handle claims for loss or damage in transit with the carrier. (See Terms and Condition of Sale)

Have an experienced machine assembler or millwright look over the goods to assess possible damage, missing parts and to estimate the kind of equipment and methods required for assembly.

Find the manual holder on the unit and remove the manual. If necessary, order from Universal more copies for other departments or users of this machine. Refer to inside back cover for various Safety Standards and Codes. Section 12 lists addresses where this manual may be obtained.



## **WARNING**

**READ THE SAFETY SECTION! FAILURE TO FOLLOW SAFETY MESSAGES COULD RESULT IN SEVERE INJURY OR DEATH.**



Read the entire manual, especially the safety instructions. Study the drawings and specifications to gain an understanding as to how the parts go together. Most machines are shipped partially assembled and require further assembly with the aid of cranes, hoists, "come-alongs", drift punches for bolt hole alignment, clamps, welding equipment, and experienced assembly supervision.



## WARNING

**Do not attempt to assemble, hoist into place, or hook up Universal machines with untrained personnel or inadequate tools and equipment. To do so invites wasted time, causes unnecessary repairs and jeopardizes the safety of all persons associated with the project. Use experienced millwrights or riggers!**

It is often necessary to connect the electrical supply to the motor in a temporary manner to check the direction of motor shaft rotation. Upon completion, if needed, reconnect, and recheck the rotational direction before making permanent connections.

***DO SO WITH MOTOR DISCONNECTED FROM THE DRIVE AND THE REST OF THE MACHINE IF AT ALL POSSIBLE.***

**To check direction of motor rotation:**

1. Warn all personnel working in the area and on electrically connected machines (possibly out of the area) that a test is pending.
2. Post observer(s) or provide for fail-safe communications between the motor location and the electrical switch.
3. If motor is disconnected from drive, take care to restrain the motor from rolling at the start due to inertial reaction. Take special care with the C-face type motor which has no mounting foot and almost a round casing. While this reaction may not be violent, if the C-face motor was insecurely resting on a ledge or support, it could roll off, creating a falling hazard.
4. If motor cannot be disconnected from the drive or the drive disconnected from the machine, be sure the machine is clear of tools, parts, and bolts and that all personnel are cleared away at a safe distance from the machine.

All guards, covers, safety signs, overload devices are to be in place and functional before starting initial run-in (empty operation) or before placing unit in service.



## WARNING

**FAILURE TO HEED ABOVE SAFE PRACTICES COULD RESULT IN SEVERE INJURY OR DEATH.**

**REQUIREMENTS**

National and local Electrical Codes have had as their main goal, the SAFE OPERATION OF EQUIPMENT. They can help you eliminate the risk of injury or equipment damage, but only if you follow them under the guidance of your local electrical inspector or qualified journeyman electrician.

There are four main areas of Electrical Safety:

1. Safeguarding the operator from physical injury by the equipment itself.
2. Safeguarding the operator from electrical shock injuries.
3. Safeguarding the wires and equipment from major current damage due to short circuits.
4. Safeguarding the operator from slightly excessive electrical current levels that can still cause fires and equipment damage.

**All four areas are important and require careful planning before installation is begun.**

***First Area of Safety-Operator Injury***

Requires the physical guarding of all moving parts of the equipment.

Electrical disconnect switches should be padlocked in the off position before work is started. Emergency stop switches should always be installed near open areas to minimize injuries from accidental contact with moving material or equipment parts. Most importantly, thorough training of all workers should be done to eliminate the accidents before they happen. Training and guarding is required by OSHA. Refer to Section 12 for various regulations that may cover the specific safety concern.

***Second Area of Safety-Electrical Shock Hazards***

Requires the installation of properly sized and protected wiring and electrical equipment. Code requirements for grounding should be followed completely, and the entire installation should be reinspected periodically to detect any deterioration in your overall exposure to these and other risks.

***Third Area of Safety-Protection from Short Circuits***

Requires the use of properly sized fuses or circuit breakers in each section of the electrical distribution system at the site, from the main disconnect to the motor. At each point, fusing cuts off power to prevent fires, personal injuries, and further damage to equipment.

***Fourth Area of Safety-Slight Current Excesses***

This area is important because the conditions that cause expensive damage are difficult to detect or prevent with either fuses or circuit breakers. Only magnetic starters with correctly sized heaters are sensitive enough to limit current in many situations. Anything else will allow a motor or its wiring to burn out at slight overloads or low voltage situations. Fuses are just not available in enough different sizes to protect the motor against these smaller overloads. Magnetic starters also can be remotely controlled with switches, including low-speed switches, emergency stop switches, and remote or automatic controls. Besides being REQUIRED BY THE ELECTRICAL CODE, magnetic controls also protect anyone working on the equipment after a power failure as it greatly lessens the chance of an unexpected start when power is restored.

 **WARNING**

**DO NOT INSTALL THIS UNIT WITHOUT A LOCKABLE ELECTRICAL DISCONNECT SWITCH**

Unit Application, location and specifications determine the type, quantity and/or placement of electrical, electrical safety or other safety controls required. Whether another supplier or the Company supplies these controls, all OSHA and health standards, the National Electric Code and the Local Codes should be considered.

**INSTRUCTIONS FOR PURCHASERS, INSTALLERS, AND DESIGNERS FOR USE OF EMERGENCY SHUT-OFF SWITCHES FOR UNITS**

The Company cannot know all the uses and applications of its units, but recommends the installation and use of one or more emergency shut-off switches on each installation. The emergency shut-off switches improve the safety for the user, the operator, and other people in the area of the unit. The installer and/or designer will have to analyze the installation of each unit, and determine the placement of, location of, and number of emergency switches necessary for each application and usage.

Emergency shut-off switches are offered by The Company in its Manual and should be ordered and installed as recommended by the installer or designer.

1. Determine the exact location of the elevator boot. Establish the up-leg and down leg sides. Consider how the boot will be cleaned out and serviced when necessary. Establish the location of the lockable disconnect switch for the person who will be cleaning or maintaining the machine. Refer to OSHA Regulation 1910.147 requiring employer to use a lockable disconnect switch.
2. Establish whether the elevator is to be fed on the down leg side or the up-leg side or both. Preferred side is the up-leg side. Experience has shown that fewer feeding problems and less product damage occurs when feeding on the up-leg side. However, lightweight (fluffy) materials load well at low positions on the down-leg side. The low position on the up-leg side is to be used as a last resort and only with free-flowing materials.



## **CAUTION**

**Positioning the hopper (inlet) high on the down leg side or low on the up-leg side may result in buckets not filling to capacity. Feeding on the down-leg side may cause the elevator to consume more power, to damage fragile products, and to be more susceptible to choking.**

3. Before starting assembly, determine the height at which the access section and the platforms (if any) will be placed. Plan for the location of safety lockout switches and/or emergency stop switches for operating, cleaning, and service personnel.
4. Assemble the elevator and erect according to the three methods listed below. As noted in Section 4, INSTALLATION-GENERAL section of the manual use experienced assembly, millwright or rigger personnel to minimize mistakes and to make the installation as safe as possible.

### **METHOD A**

Assemble the elevator completely at ground level (horizontal). Hoist the assembly into position (vertical), using legging reinforcements, two lift points to distribute the load. If equipped with a ladder, weld the ladder ends together to stiffen the elevator.

### **METHOD B**

Assemble the elevator upward, starting with the boot section. Place access section and different legging lengths as desired. Run a cable or rope over the head pulley (top), attach the cable to the belt or belt and bucket assembly and pull the belt into the elevator by pulling down over the head pulley.

### **METHOD C**

Bolt the head assembly and one or two sections of legging together as a subassembly. Pull the belt around the head pulley. As the unit is lifted with a crane, slip sections of legging over belt ends and bolt into position from underneath.

**Be sure buckets are installed for operation in the correct direction!**



## **WARNING**

**Guy or brace the standing sections of the elevator to prevent swaying or collapse during erection. Attach guys to leg, not ladders or platforms! Use two or three cable clamps per end of guy. Guard against sharp anchor holes cutting the cable by using any practical means including the use of cable thimbles. Failure of the guy system may cause serious injury or death.**

## SECTION 6

## ELEVATOR INSTALLATION

### FOR ALL METHODS:

Brace the head section permanently when erection is complete. Guy or brace the elevators at 20 to 30 foot intervals below the head section, using 5/16 inch or 7/16 inch diameter galvanized wire rope. The top guys should make an angle of at least 30 degrees or more with the trunking and be guyed in four equally spread directions. Align the outer edges of the trunk coupling to assure that the buckets will not catch on interior projections. Install bolts (grade 5 or better furnished) in all holes provided in coupling. Grade 5 bolts have superior strength and can be identified by the industry standard three (3) marks on their head.

If required, weather or dust sealant is available from the Company. If the sealant was previously ordered, it would have shipped with the unit. Prior to attaching the next coupling, apply a 1/8" diameter bead of sealant to the trunking coupling face.

Use a transit instrument from in two different directions (side and front or back) or a plumb bob. To check the plumb and straightness of the finished installation. **IT IS IMPORTANT THAT THE ELEVATOR IS PLUMB AND STRAIGHT!** A plumb, straight elevator will be more durable, quieter, and less expensive to operate because the contact of the bucket/belt assembly with trunking will be minimized.

### INSTALLER CHECKLIST:

- All guards and covers are in place? Are lockable electrical disconnect switches installed properly?
- Are all warning signs visible-not painted over or badly scratched? If not, order and install new safety warning signs.
- Are the set screws tight? (See Section 4).
- Is the motor wired for correct rotation? (See Section 4)
- Is the reducer backstop installed to allow correct rotation? (if a backstop is necessary or provided)
- Does reducer have the correct kind and amount of oil? (See reducer manufacturer's recommendations)
- Are all of the tools, excess nuts and bolts, and spent welding electrodes, etc., cleared out of the elevator?
- Are inlet(s) guarded per safety standards, codes and good practice?
- Deliver this manual to the person responsible for the operation and maintenance of the elevator. Get additional copies made or order them from the Company. If the installer is a third party, good business practice suggests that a written statement be signed by the installer stating that this manual exists and was read for installation information and turned over to the permanent owner/operator of the elevator.

**Before running the unit, operate unit empty for several hours. While doing this, recheck the tightness of bucket bolts, the bar clamp belt splice, bearing and reducer setscrews, pulley fasteners, drive component temperatures and signs of normal grease leakage from around bearing seals (a small bead of visible grease is desirable).**



## WARNING

**LOCK POWER OFF BEFORE CHECKING ABOVE ITEMS. Replace all covers and guards before putting elevator into service. Failure to do so may cause serious injury or death.**



## WARNING

**FAILURE TO INSTALL EMERGENCY SHUTOFF SWITCHES MAY CAUSE SERIOUS INJURY OR DEATH.**

**Emergency Stop Switches must be used on all systems.**

The Company ships an Emergency Shutoff Switch as standard equipment on **all systems**.

## SECTION 7

## BELT SPLICE & BUCKET INSTALLATION

Typically, upon installing a new belt, the pads and the buckets are fastened to the belt at ground level near the elevator. Then, the completed assembly is pulled up into the elevator legging. Another method of bucket installation is to pull the belt into the elevator, install splice, and then bolt the pads and buckets onto the belt by working through the access section opening. This latter method is similar to a maintenance operation where buckets, bolts, pads and the belt are examined or parts exchanged.



### DANGER

**LOCK POWER OFF IF ASSEMBLING BUCKETS AND PADS TO A BELT ALREADY INSTALLED IN THE ELEVATOR.**

**Elevators that do not have power connected can also be dangerous due to unbalanced belt assemblies running away when not sufficiently anchored. Assemble only a few buckets at a time, leaving many spaces or gaps, filling in these empty spaces as they present themselves on succeeding revolutions. Failure to do so may cause serious injury or death due to uneven distribution of weight.**

Most models have buckets installed on each set of holes. Consult the specifications page in Section 11 on this model for the bucket spacing. Be sure buckets are installed to discharge over the down-leg side!

Bucket cushions or washers are provided for installation between the buckets and the belt. Be sure bucket cushions are placed so their upper edge is even with the top edge of buckets. Tighten the bucket bolts evenly until the bolt head is embedded into the belt. Do not over tighten so that the belt bulges between the bolt heads. A six point deep socket is the nut runner of choice.

### INSTALLING THE BAR-CLAMP BELT SPLICE



### WARNING

**DO NOT USE A LAP-SPLICE OR A BUTT-SPLICE IN A UNIVERSAL ELEVATOR. ALWAYS USE A UNIVERSAL BAR-CLAMP SPLICE. FAILURE TO USE THE BAR-CLAMP SPLICE COULD RESULT IN SERIOUS INJURY OR DEATH.** Less reliable splices could fail, dropping the belt assembly into the legging, possibly causing legging rupture and elevator collapse in the case of tall units.

## BELT SPLICE & BUCKET INSTALLATION

Steps to installing a bar-clamp splice (see illustration).

1. *For Boot Take-up Systems:* Raise boot pulley to the upper limit of travel of the take-up bolt.  
*For Top Take-up Systems:* Lower head pulley to the upper limit of travel of the take-up bolt.
2. Use belt-stretching equipment (if available) to draw the belt tight.
3. Pull the ends of the belt between the halves of the bar clamp and loosely clamp the belt with screw-clamp tools.
4. Pull the belt between the bar-clamps as far as possible by tapping the bar-clamps with a hammer while pulling on the belt ends. Make sure that the bar clamps are exactly perpendicular to the edge of the belt. Do not allow unused bucket-bolt holes to be in or near the bent portion of the belt.
5. Tighten screw-clamp tools securely and drill 3/8" holes in the belt using the holes in the bar-clamps as guides. Use a sharp drill to get clean holes.
6. Trim excess belt not closer than 1/4" from bar-clamps.

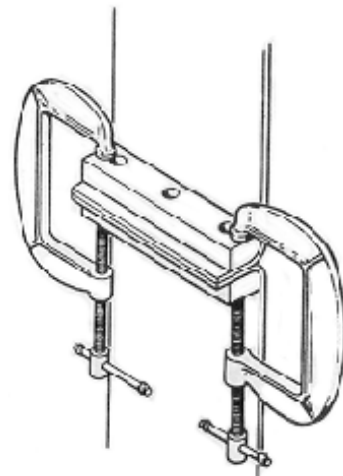

After the belt is installed, check to see that it is correctly aligned on the head and boot pulley. The belt should be tense at the boot pulley. Slackness due to initial stretch should be taken out and the take-up pulley should be placed in its highest position before completing installation.

 **WARNING**

**NEVER MAKE THE INITIAL CHECK OF THE BELT ALIGNMENT WHEN THE ELEVATOR IS RUNNING AT FULL SPEED OR LOADED WITH PRODUCT.**

Jogging the elevator, for observing and correcting belt tracking, requires that one or more covers be removed, both at the head (top) and the boot (bottom) of the elevator.

1. Warn all personnel in the area to stay clear, including any near the machines that may be electrically connected with the elevator.
2. Use only experienced and trained personnel to conduct observations and adjustments.
3. Use extreme caution and keep at a safe distance from the elevator.
4. Often, both top and bottom ends of the elevator may be out of sight or hearing from the starting equipment. It is absolutely necessary to establish a fail-safe communication arrangement whether it be hand signals or a radio/telephone system.
5. Lock out power during adjustments, then repeat #1 (above) when rechecking belt tracking by jogging.

**FAILURE TO FOLLOW THESE AND OTHER SAFE PRACTICES DURING THE ALIGNMENT/ADJUSTMENT COULD RESULT IN SERIOUS INJURY OR DEATH. ONLY TRAINED PERSONS USING EXTREME CAUTION ARE TO ATTEMPT THIS PRACTICE.**

**MISTRACKING:**

*For Boot Take-up Systems:*

If the belt is mistracking at the head (top), add belt shims under the bearing toward which the belt runs off. If mistracking at the boot (bottom), turn down on the take-up bolt on the side toward which the belt runs off.

*For Top Take-up Systems:*

If mistracking in the head, turn up the take-up bolt on the side toward which the belt runs off.

**EXPERIENCED INSTALLERS SHOULD RUN THE ELEVATOR FOR A DAY OR MORE CHECKING ON BELT ALIGNMENT, BELT TENSION, BAR-CLAMP SPLICE AND BUCKET BOLT TIGHTNESS BEFORE PUTTING THE UNIT INTO SERVICE.**

 **WARNING**

**ALL COVERS AND GUARDS MUST BE IN PLACE WHILE PERFORMING EMPTY RUN-IN AND ALSO BEFORE PUTTING THE UNIT INTO SERVICE. FAILURE TO DO SO MAY CAUSE SERIOUS INJURY OR DEATH.**

Start-up and empty run-in period:

The start-up or installation period is not to be confused with an empty run-in period.

The start-up or installation adjustment period is period when only skilled installers using safe practices apply electrical energy to the machine to observe direction of rotation and belt tracking in order to make adjustments. This is quite often and necessarily done with covers and guards removed for visual inspection.

 **WARNING**

**ONLY TRAINED PERSONNEL USING SAFE PRACTICES SHOULD BE ALLOWED TO PERFORM START-UP ACTIVITIES!**

The **empty run-in** period is that phase of installation after the initial installation adjustment activity when all guards and covers are placed into position and the unit is run without carrying product. The purpose is to allow a few hours of **break-in** to reveal whether further adjustments are required before putting the unit into service. Care must be taken that all personnel working nearby are instructed that the machine is operating and that safeguards be taken to prevent exposure to the machine through connecting chutes. Typically, the trained personnel keep the machine under observation. This period is when loose fasteners, overheating and unusual sounds are discovered. A valuable and early chance to correct problems before production start-up.

 **WARNING**

**ALL COVERS AND GUARDS MUST BE IN PLACE WHILE PERFORMING EMPTY RUN-IN AND ALSO BEFORE PUTTING THE UNIT INTO SERVICE. FAILURE TO DO SO MAY CAUSE SERIOUS INJURY OR DEATH!**

**GENERAL** **WARNING**

**LOCK POWER OFF** before performing inspections and maintenance. When it is necessary to observe the elevator while running, use utmost care in keeping clear of the machine. Keep other personnel away from the area and be sure that other electrically connected equipment is also isolated from harming personnel. Never service this machine while it is in use. Use a buddy system with another experienced person who also can lock out the disconnect with his/her personal padlock. Use failsafe methods of communication, whether it be visual, radio or shouted messages. Restore all covers and guards before returning unit to operation. Replace missing, damaged or painted over safety signs with new ones from the Universal Industries.

**FAILURE TO FOLLOW THESE INSTRUCTIONS COULD RESULT IN SERIOUS INJURY OR DEATH.**

Good belt alignment in a properly erected and plumb elevator is necessary for optimum operation of the machine. The bolts on the bar-clamp splice will probably need to be re-tightened after about 10 hours of operation.

The belt can be expected to stretch from about 1 to 1.5%, mostly during the first few weeks of operation. Check the belt frequently at first and use the take-up bolts to eliminate slack.

 **WARNING**

**FAILURE TO FOLLOW THESE INSTRUCTIONS COULD RESULT IN SERIOUS INJURY OR DEATH.**

Never allow belt to hang below the boot pulley. If allowed, a slack belt may fold in the boot causing buckets to jam and stall the elevator. This may cause a belt failure at head (top) pulley, dropping the belt assembly into the elevator trunking.

When the take-up bolts will not tighten enough, shorten the belt accordingly. When shortening the belt, always trim the excess at both ends of the belt.

**PERIODIC INSPECTION**

Periodically inspect the drive system for worn, misaligned or loose belts and/or chains. Examine the unit for loose nuts and bolts. Make sure that the electrical wiring, contacts, switches, etc., are in good operating condition. Worn chains will ruin sprockets quickly. Consult manufacturers' instructions on gear reducer drives regarding oil levels, oil changes, and, if equipped, backstops.

 **WARNING****BACKSTOPS**

On elevators equipped with a backstop (anti-backwards running device), check at each lubrication or inspection interval to see if the backstop is working. Lock power off and remove drive guard. Try to run elevator backwards by pulling on the v-belts, using extreme caution not to pinch fingers. If any backward motion is allowed, service the backstop. The backstop device is usually enclosed in the Shaft Mounted Speed Reducer and is accessible through a cover on the backside of the gear reducer on the opposite end of the input shaft. On very small elevators that employ a second (counter) shaft and pulleys for speed reduction, the backstop is a device mounted on the outer end of the elevator main (head) shaft on the side opposite the input sprocket or pulley. This device is restrained from turning backwards by a link and arm arrangement. Inspect the condition of the arm and the link.

The purpose of the backstop is to restrain the elevator from idling backwards in the event of a power failure while the unit is handling product. On very tall or heavily loaded units, the loaded buckets would move downward, discharging their contents in the boot. There would be no place for the material to go. If large forces are present, the boot, buckets and belt may be badly damaged. If the boot would suffer structural damage, the elevator could collapse. Do not restore the elevator to service after inspection or repair until all covers and guards are in place.



**BACKSTOPS****WARNING****FAILURE TO FOLLOW THESE PRECAUTIONS COULD RESULT IN SERIOUS INJURY OR DEATH.**

Periodically check the elevator for vertical position. Inspect guys and braces, looking for corrosion, abrasion, cuts and tightness. Occasionally, check the condition of the belt and see that it is centered on the head and boot pulleys. Straighten or replace damaged buckets.

**BAR-CLAMP SPLICE**

The bar-clamp splice requires no maintenance other than tightening after the first 10 hours of operation. However, replace the belt if the belt begins to wear or becomes thin behind the splice.

**OPERATING SUGGESTIONS**

When a sluggish material is going to be elevated, install a shut-off slide at the top end of any chute leading to the hopper. This will allow the material to gain some speed before it enters the elevator, and thus reduce any tendency it has to stall in the chute.

Rapid flowing heavy materials can push the belt over against the boot casing side if the stream goes in at a sideways angle to the bucket path. Try to arrange for the material to enter straight into the buckets. This will result in better bucket filling and less material going down into the bottom of the boot to be scooped up again.

To check whether the elevator is operating at or near capacity, open the slide on the inspection section. If there appears to be a good deal of spillage, then the buckets are at or near capacity. The lower the inspection section is located, the more spillage can be expected out of the inspection opening. Spillage out of the inspection opening does not necessarily mean that the buckets are full or reaching a choked condition. The only actual way to accurately determine the volume being elevated is by making a timed run on a known volume of material.

**BEARING LUBRICATION**

Most equipment is furnished with bearings that can be relubricated. The bearings will have grease fittings installed. If the bearing does not have grease fitting, it is a lubricated-for-life bearing and requires no further service except setscrew tightness check.

If the bearing is exposed to wet or dust conditions or to corrosive vapors, extra protection is necessary. Add grease until it shows at the seals. If possible, rotate the bearing to distribute the grease. Provide a removable cover for the bearing if dust, sand or moisture tends to wick away lubricants or attack the seals. The cover should be easily removed so the greasing process can be observed at the seals.

Most products operate at moderate to low shaft speeds and under normal dust conditions. This means that the bearing should be as full of grease as possible. The bearings are shipped from the factory greased and ready to run. When establishing a relubrication schedule, note that a small amount of grease at frequent intervals is preferable to a large amount at infrequent intervals. The Bearing Lubrication Table on page 8-3 is a general guide for relubrication. However, certain conditions such as high surrounding temperatures, excessive dust or wet conditions, may call for different lubrication schedules or different lubricants. If premature bearing failure is experienced, consult Universal Industries or an experienced bearing distributor.

## SECTION 8

## OPERATION & MAINTENANCE

### LUBRICATION INSTRUCTIONS

All ball Bearing Units are factory lubricated, ready for use. In extremely wet applications, additional grease may be added to completely fill the bearing cavity.

For general purpose applications, use a #2 consistency Lithium Base grease formulated from a high quality mineral oil with rust and oxidation inhibitors.

Examples:

Mobilith AW2	Texaco Premium RB
Mobilux #2	Exxon Unirex N2
Shell Alvania #2	Amoco Amolith 2
Texaco Multifak #2	

The table below is a general guide for relubrication. When relubricating bearings, add grease slowly while shaft is rotating. When grease appears at the seal area, the bearing contains the correct amount of lubricant. Bearings should operate at temperatures less than 200° F (93° C) and should not exceed 225° F (107° C) for intermittent operation.

### BEARING LUBRICATION GUIDE

Operating Conditions	Bearing Temperatures	Grease Interval	Recommended Grease
Clean	32°F to 120°F 120°F to 150°F 150°F to 200°F	6 to 10 Months 1 to 3 Months 1 to 4 Weeks	Shell Alvania #2 Texaco Multifak #2 Mobil Mobilux #2
Dirty	32°F to 120°F 150°F to 200°F	1 to 4 Weeks Daily - 1 Week	
Moisture	32°F to 200°F	Daily - 1 Week	

### CHECK SETSCREW TIGHTNESS

At the time of machine installation, it is necessary to check tightness of the two bearing setscrews that lock the bearing collars to the shafts. The setscrews should be tightened alternately and in small increments to the torque specified in the Bolt and Setscrew Torque Value Table on page 8-4. *After the initial 24 hours of operation*, the setscrews should be re-tightened to the torque values in the same table on page 8-4 to assume full locking of the inner race to the shaft. Care should be taken that the socket key or driver is in good condition with no rounded corners and that the key is fully engaged in the setscrew to prevent rounding out of the setscrew socket when applying maximum torque. If a torque wrench is not available, the proper torque can be approximated by using a socket key with sufficient force to spring the key without permanently deforming the key.

**BOLT AND SETSCREW TORQUE VALUES**

SETSCREWS				BOLTS-GENERAL	
Key Hex Recommended					
Across Torque (in-lbs.)				Wrench Torque	
<u>Size</u>	<u>Flats</u>	<u>Min</u>	<u>Max</u>	<u>Size</u>	<u>Inch-lbs.</u>
No. 10	3/32	28	33	3/8-16	240
1/4	1/8	66	80	1/2-13	600
5/16	5/32	126	156	5/8-11	1200
3/8	3/16	228	275	3/4-10	2100

Also at this time, check the tightness of bolts securing pulley and sprocket hubs.

It is a good idea to operate the machine for several hours with **all guards and covers in place**, but with no product being conveyed. This should be done without other noisy machinery turned on. Installation personnel should be close by to be watchful for malfunctions. Unexplained machine noises, excessive lubricant leakage, belt mistracking, motor overheating and other problems can often be detected and corrected inexpensively before putting the unit in service.

## SECTION 9

## AVC-AIR CLEANOUT OPERATION

Follow the prescribed AVC assembly instructions, referring to the exploded parts drawing for the correct assembly of plumbing components. The boot shaft should be adjusted so that there is at least one full elevator bucket spaced below the inlet opening in the elevator boot. Lengthening the belt may be required to achieve the necessary boot shaft position. Adjust the AVC cleanout strap so there is approximately one inch of clearance between the strap and buckets. Ideally, the arc AVC cleanout strap should be positioned onto the bottom of the boot with the belt and bucket assembly lowered to the AVC strap, leaving a minimum of one inch above the AVC strap.

### CAUTION

**The AVC can only be installed on the "down leg" elevator side of the boot for it to function properly. Installations of the AVC on the "upleg" elevator side of the boot will cause the boot to not clean out properly and may cause damage to the elevator.**

### CAUTION

**Over tensioning the elevator belt may cause excessive loads on elevators shafts and bearings, which may cause premature failure of these components.**

### CAUTION

**Adjusting the AVC strap up to an improperly positioned bucket and belt assembly will create a strap arc that deflects the airflow direction away from the remaining product, causing cleanout failure.**

Power requirements:

AIR	95-120 psi ½" diameter air line (minimum)
Electrical	24vdc or 120vac

Using the air regulator supplied with the AVC Kit and the solenoids energized, adjust the air pressure according to Table 1. Air pressure and volume depend upon product density, shape and size. Table 1 will provide a guideline from which to determine the appropriate regulator setting for your AVC application.

### WARNING

**Never make the initial check of the elevator loaded with product. Use eye protection to avoid serious injury during assembly and operation on any machinery.**

### CAUTION

**Too much pressure will suspend the remaining product up into the elevator inlet, causing cleanout failure.**

#### **AIR CYCLING AVC OPERATION:**

This operation is performed after stopping the flow of material into the elevator and the elevator buckets are unable to pick up the remains of material left in the boot.

Energize the air solenoid valve and allow the air to sweep the material up toward the elevator inlet where the buckets will lift the remaining material away to the discharge. We recommend cycling periods of "air on" and "air off", beginning with a 15 second "air on" period, followed by a 15 second "air off" period. Elevator capacity and discharge height effects the on/off cycling duration. Larger capacity elevators will accumulate more material in the boot and may require a longer "air on" cycle duration. Taller elevators require more time for the last buckets of the "air on" cycle to reach the elevator discharge, adding to the "air off" cycle duration. For example, some applications may require an "air on" cycle for 15-20 seconds, while the "air off" cycle may be as long as 30 seconds, or more. The number of cycle periods may also vary. Three or four cycle periods will usually achieve the desired cleanout effects. Operator experimentation with air pressure and with the "air on" and "air off" cycling periods may be necessary to achieve the desired cleanout effects.

**WARNING**

**LOCK POWER OFF BEFORE REMOVING COVERS OR OPENING THE BOOT DOOR TO INSPECT THE ELEVATOR.**

To verify that the boot is clear of material, open the boot door, lower the cleanout strap attached to the boot.

MODEL (ELEVATOR)	PRESSURE (PSI)	VOLUME (CFM)
B3/U	10-15	10-15
C3/U1	10-20	10-20
C6	15-25	15-30
U2	15-25	15-30
D3	15-25	15-30
E/U3	25-45	25-45
DD/U6	35-55	35-55
F10	40-65	40-65
P850	15-25	15-30
P1300	20-40	20-40
P2800	25-45	20-45

Table 1

**VACUUM CLEANOUT OPERATION:**

AVC kits are supplied with a 2.5" vacuum port tube stub, to vacuum out the fine debris that accumulates below the AVC strap. The larger elevators (C6 and larger) have a secondary air manifold which assists the vacuum cleanout. This secondary manifold is connected to a solenoid, which is connected to the same air plumbing used for the primary AVC manifold.

**WARNING**

**ENERGIZING THE SECONDARY AIR MANIFOLD SOLENOID WILL PRESSURIZE THE AREA BELOW THE AVC STRAP. A CAP OR HOSE TO VENT THE AIR AWAY TO A SAFE AREA, MUST BE IN PLACE ON TOP OF THE VACUUM PORT TUBE STUB. IN NOT, MATERIAL CAN BE PROJECTED FROM THIS TUBE STUB, WHICH MAY CAUSE INJURY OR DEATH.**

Periodic vacuum cleaning below the AVC strap is recommended to insure the best operation of the bucket elevator.

Vacuum cleaning can be preformed manually with a "shop-vac" or setup for automatic cleaning with the central vacuum system or dust collection system, installed in your plant.

Automatic vacuum cleanout requires some synchronization of the vacuum system with the secondary air manifold solenoid (models with air-assist). Vacuum cleanout can be scheduled during the main AVC cleanout cycling periods. However, vacuum cleanout could be scheduled once or twice a week, depending on the amount of material run through the elevator over a given period of time. This cleanout period may last several seconds to a minute or more, depending on the frequency of cleaning and the amount of material collected in the elevator boot. The operation should a steady continuous vacuum and blast of regulated air (models with air-assist) until the area beneath the AVC strap is satisfactorily cleaned of debris. The regulated air pressure setting for the secondary air manifold is to be adjusted to the same pressure setting as the primary air manifold.

**BOOT ADJUSTMENTS:** **WARNING**

**BEFORE INSTALLATION OF THE AIR/VACUUM CLEAN-OUT KIT BE SURE THAT THE ELEVATOR IS COMPLETELY EMPTY OF PRODUCT.**

**WHENEVER WORKING WITH ELECTRICITY, EXTREME CAUTION SHOULD BE USED. POSSIBILITY OF ELECTRICAL SHOCK IS ALWAYS EVIDENT.**

**DISCONNECT, LOCKOUT AND TAG OUT ELECTRICAL POWER BEFORE SERVICING. FAILURE TO DO SO MAY CAUSE SERIOUS INJURY OR DEATH.**

 **CAUTION**

**WEAR APPROPRIATE SAFETY GEAR.**

 **CAUTION**

**METAL FILINGS AND DUST WILL BE AIRBORNE.**

**REMOVING OF EXISTING PARTS:**

Remove the spout hopper, clean-out slide, and the panels on both the up and down leg sides of the elevator. See Illustration 1A on Page 9-7 for help in identifying these panels.

**MODIFICATION TO THE EXISTING BOOT:**

A stiffener strip attached to the lower boot flange needs to be cut out to make room for the down leg wedge slide and the vacuum wedge.

 **CAUTION**

**NATIONAL AND LOCAL ELECTRICAL CODES HAVE HAD AS THEIR MAIN GOAL THE SAFE OPERATION OF EQUIPMENT. THEY CAN HELP YOU ELIMINATE THE RISK OF INJURY OR EQUIPMENT DAMAGE, BUT ONLY IF YOU FOLLOW THEM UNDER THE GUIDANCE OF YOUR LOCAL ELECTRICAL INSPECTOR OR QUALIFIED JOURNEYMAN ELECTRICIAN. TO ASSURE PROPER INSTALLATION, A QUALIFIED PNEUMATIC TECHNICIAN SHOULD BE ON HAND TO SETUP THE PIPING AND CONNECT THE AIR PRESSURE.**

## SECTION 9

## AVC-AIR CLEANOUT OPERATION

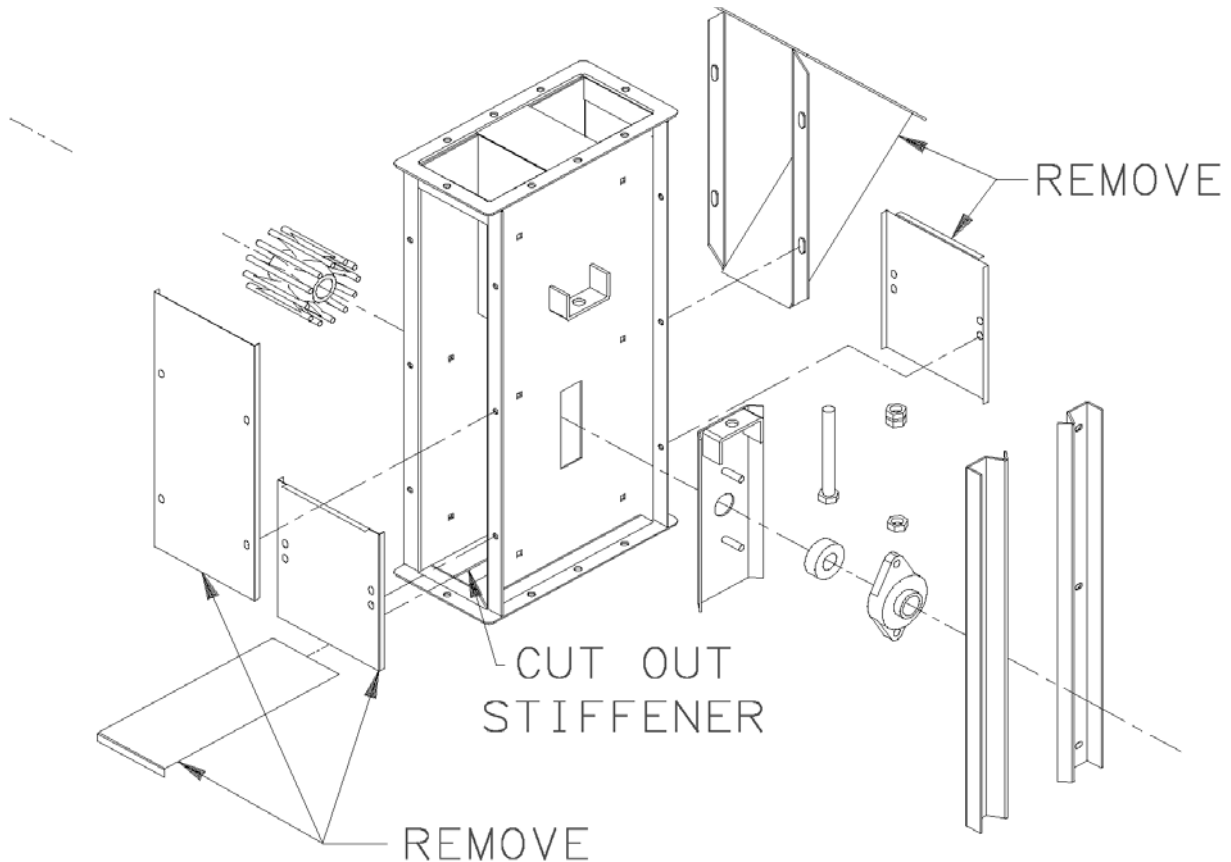

ILLUSTRATION 1A

### ATTACHING/ASSEMBLING OF THE AIR/VACUUM CLEAN-OUT EQUIPMENT:

The exploded parts drawing labeled Illustration 1B on Page 9-5 and a parts list labeled 1C on page 9-6 will help in identifying parts for assembling the AVC kit. Teflon tape over the pipe threads will help in sealing the plumbing of possible air leaks.

1. Attach the door #5 to the frame #4 with hinges already welded and in place.
2. Thread the 1/2" tube fitting #11 into the air manifold on the primary air manifold #3.
3. Align the door #5 and frame #4 with the primary air manifold #3 and the latch mount #6. Bolt this unit to the boot using (2) 1/2" screws & (2) nuts. Note: Door can hinge either right or left.
4. Bolt vacuum wedge #2 to the boot on the up leg side of the elevator using (2) 1/2" screws & (2) nuts.
5. Bolt the down-leg wedge slide #1 to the elevator using (2) 3/4" screws & (2) nuts. NOTE: This piece will overlap the lip on the vacuum wedge #2.
6. Locate pipe coupling #15 and connect to it a two (2") inch nipple #13, next connect a standard 3/8" pipe elbow #14.
7. A one (1") inch pipe nipple #12 connects to the 3/8" pipe elbow #14; following that in order will be a 120V AC/(24V DC) solenoid #9, another one (1") inch pipe nipple #12, and finally the regulator #7. NOTE: An arrow on the solenoid #9 and the regulator #7 indicates direction of air flow. Insert the regulator plug on the opposite side from the regulator regulator gage.
8. Locate two (2) 5/8" flat washers #17 and a 1/2" tube fitting #11. Push out one of the knockouts on the side of the door frame #4 nearest to the top, either the right or the left side, whichever application works best for your needs. Connect the tube fitting #11 through the frame #4 and into the pipe coupling #15.
9. Cut tubing to required length and insert the tubing into the manifold fitting routing under strap positioning bracket. NOTE: To release the tubing in the tube fitting #11 and the union-elbow #16 push down on the black ring and pull the tube.
10. Slide strap #18 into the boot over bottom wedges and hook onto the vacuum wedge #2. Align J-hook bolt into the positioning bracket.

Continued on Next Page--->>

## WARNING

EDGES ARE SHARP. GLOVES SHOULD BE WORN WHEN INSTALLING AND REPOSITIONING THE CLEAN-OUT STRAP (#18).

11. Reattach hopper.
12. Adjust strap by lifting it up into the buckets, then backing it down by at least one stop on the positioning bracket.

## WARNING

ELECTRICAL SHOCK. A QUALIFIED ELECTRICIAN SHOULD CONNECT WIRING FOR THE SOLENOIDS.

13. Connect the wires for the solenoids.
14. Connect air line hose to the system.

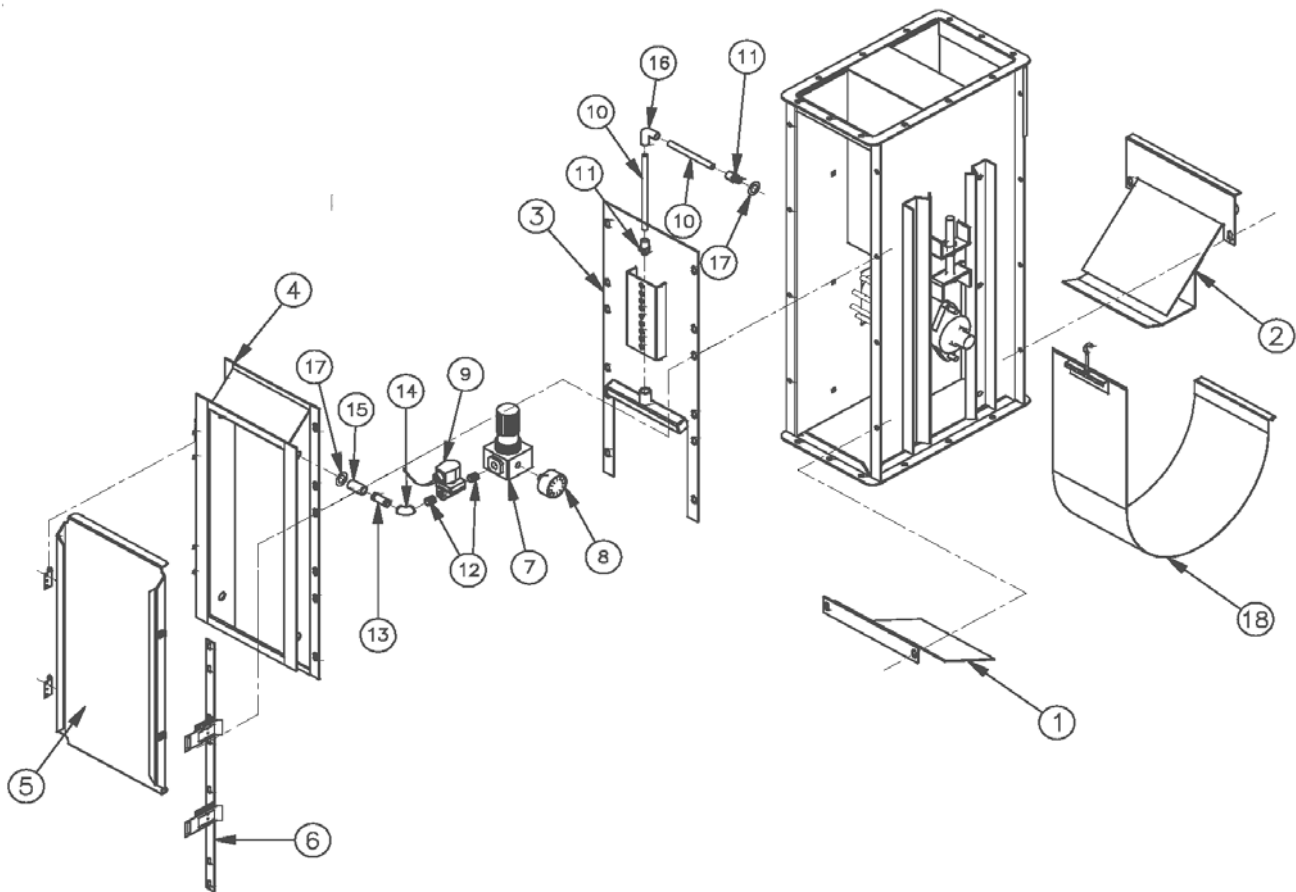

ILLUSTRATION 1B



**SECTION 9****AVC-AIR CLEANOUT OPERATION****Model B3/U AVC Parts List**

INDEX NO.	PART NO.	DESCRIPTION	QTY.
	30077	CLEANOUT,AVC,KIT,B3/U,CS,DC (INCLUDES ITEMS 1 THRU 18)	1
	30349	CLEANOUT,AVC,KIT,B3/U,CS,AC	1
1	35976	WEDGE,DL,AVC-MODEL B3/U	1
2	39800	WEDGE,ASSY,UL,AVC-MODEL B3/U	1
3	42745	MANIFOLD ASSEMBLY, PRIMARY AIR MANIFOLD MODEL B3/U	1
4	39803	FRAME ASSEMBLY DOOR, MODEL B3/U	1
5	35971	DOOR ASSEMBLY0MODEL B3/U	1
6	35696	LATCH MOUNT ASSEMBLY-MODEL B3/U	1
7	35804	REGULATOR, AIR,0.375"	1
8		GAGE,REGULATOR,AIR,0.375"	1
9.1	35900	SOLENOID,0.375 120V AC (3116.121)	1
9.2	35902	SOLENOID,0.375 24V DC (3116.241)	1
10	35778	TUBING,0.500" OD SEMI-RIGID,NYLON (2870.5)	5FT
11	35776	FITTING, 0.500" ODX0.375NPT,STRAIGHT,LEGRIS (2870.30)	2
12	35570	FITTING,NIPPLE,0.375X1.00,GALVANIZED (2701.310)	2
13	39283	FITTING,NIPPLE,0.375X2.00,GALVANIZED (2701.330)	1
14	35772	FITTING,ELBOW,0.375,GALVANIZED (2701.200)	1
15	35773	FITTING,COUPLING,0.375,GALVANIZED (2701.200)	1
16	35774	FITTING,0.500"OD TUBE TO TUBE,UNION-ELBOW,LEGRIS (2870.10)	1
17	30414	WASHER,FLAT,0.625 (2865.1)	2
18	32356	STRAP,ASSEMBLY,CLEANOUT-MODEL B3/U	1

**PARTS LIST 1C**

## SECTION 10

## PROBLEM DIAGNOSIS

TROUBLE	PROBABLE CAUSE	SUGGESTED REMEDY
Not Operating at Rated Capacity	1. Hopper or feed inlet not installed correctly.	1. Arrange to have material enter boot high on the up-leg side or low on the down-leg side.
	2. Material bridges and will not flow into bucket path fast enough.	2. Arrange feeding method to allow material to drop into the hopper at elevator capacity avoiding overfilling and consequent bridging.
	3. Headshaft RPM incorrect.	3. Check capacity table for correct RPM; change sheaves or sprockets as necessary.
	4. Buckets caked up.	4. Clean out buckets and if condition persists substitute stainless steel or plastic buckets.
	5. Air coming up the spout from the bind forces down legging of light material.	5. Vent the bin or the spout.
Elevator stalls or plugs up.	1. Belt slack not taken out; bucket jam in the boot.	1. Shorten belt; adjust take-up bolts.
	2. Not enough power or incorrect heater coils in the starter; motor wired incorrectly.	2. Check power requirements; have competent electrician check circuits & heaters.
	3. Elevator discharge or spouting plugged up.	3. Check for foreign material lodged in discharge chute, valves or spouting. Check spouting for bad turns which may hold up flow of material.
	4. Bins get overfilled.	4. Install an overflow box, or bin level indicator.
Noisy operation; buckets rattle in leg casing and boot	1. Elevator out of plumb.	1. Set elevator straight & plumb. Use steel cables for guying in place of wire, which will stretch & loosen. Arrange elevator braces so they are not forced out of alignment when attached to structures or bins which may shift as they are loaded & unloaded.
	2. Belt too loose or not centered on pulleys	2. Shorten belt, adjust take-up bolts, shim under head shaft bearings. See Sect. 7.
	3. Loose or deformed buckets	3. Repair or replace buckets.

**B3 BUCKET ELEVATOR**

Up to 375 CFH (10 CMH) / 300 BPH

<b>MODEL</b>	<b>B3-75ED</b>	<b>B3-200</b>	<b>B3-300</b>
Capacity - Free Flowing Material @100% Water Fill Line	75 BPH 94 CFH 2.7 CMH	200 BPH 250 CFH 7.0 CMH	300 BPH 375 CFH 10 CMH
Short TPH @ 50 lbs. ft <sup>3</sup>	2.25	6.25	9.25
Short TPH @ 75 lbs. ft <sup>3</sup>	3.5	9.3	14.0
Belt Speed	82-98 FPM	185 FPM	270 FPM
Headshaft RPM	70-90 RPM	170 RPM	250 RPM
Bucket Spacing	3 1/4"	3 1/4"	3 1/4"
Head Casing	14 gauge		
Headshaft Diameter	1 3/16" diameter		
Headshaft Bearing	Ball Bearing Pillow Block		
Head Pulley	4 1/4" diameter with vulcanized rubber lagging		
Buckets	3 3/4" x 3" HDPE, Nylon, Urethane , 14 or 18 gauge steel		
Belting	4" wide Uni-Stock, Uni-Ply, PVK, or Low-Temp		
Trunking	16 gauge twin box columns		
Boot Casing	12 gauge		
Bootshaft	1 3/16" diameter		
Bootshaft Bearing	1 3/16" Two bolt flange		
Boot Pulley	Slatted self cleaning style		
Construction	Carbon, galvanized or 304 stainless steel		
Drive Package	Optional		
Motor	Optional		

# B3 BUCKET ELEVATOR

Up to 375 CFH (10 CMH) / 300 BPH

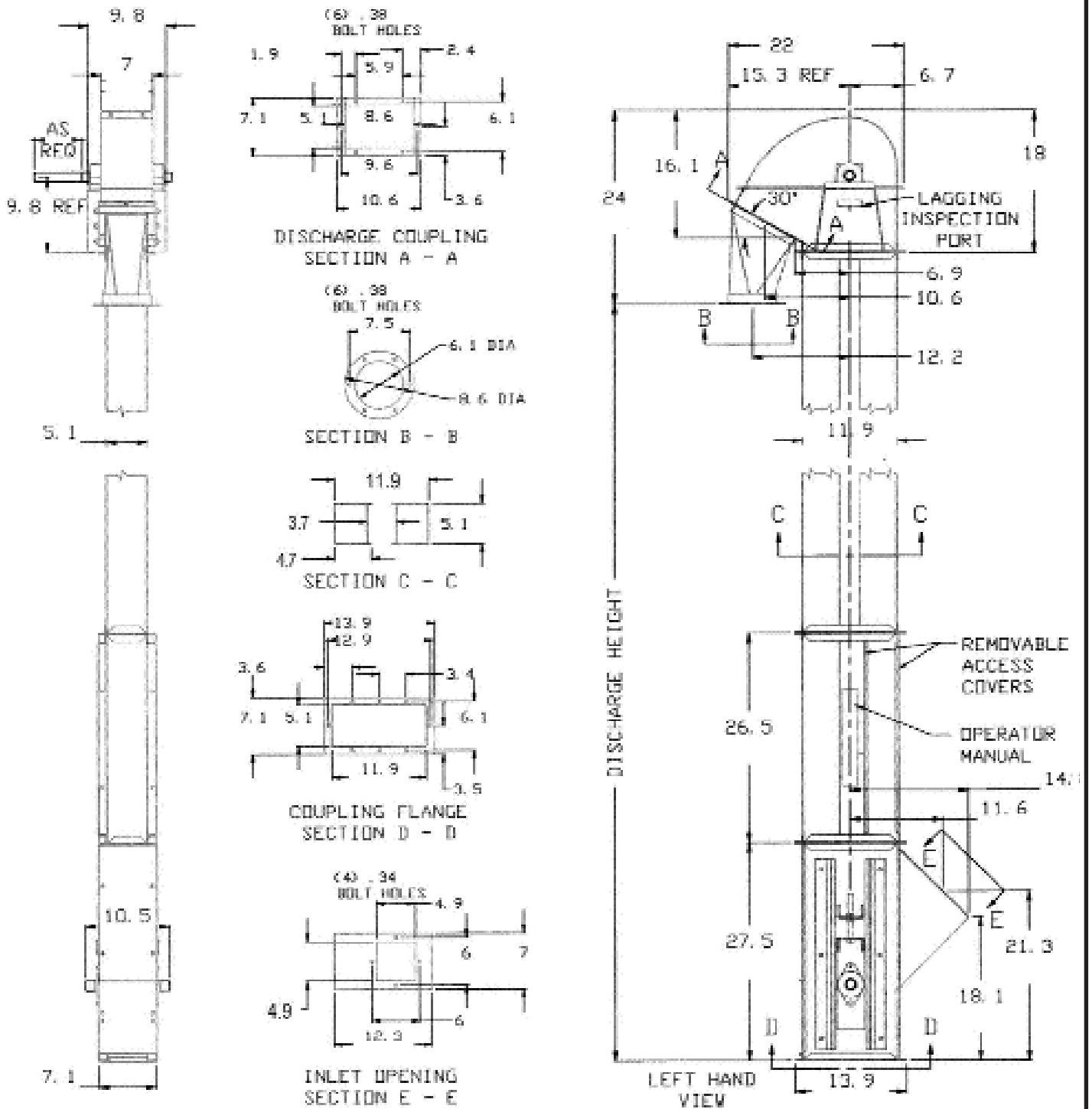

**DUMP HOPPER**

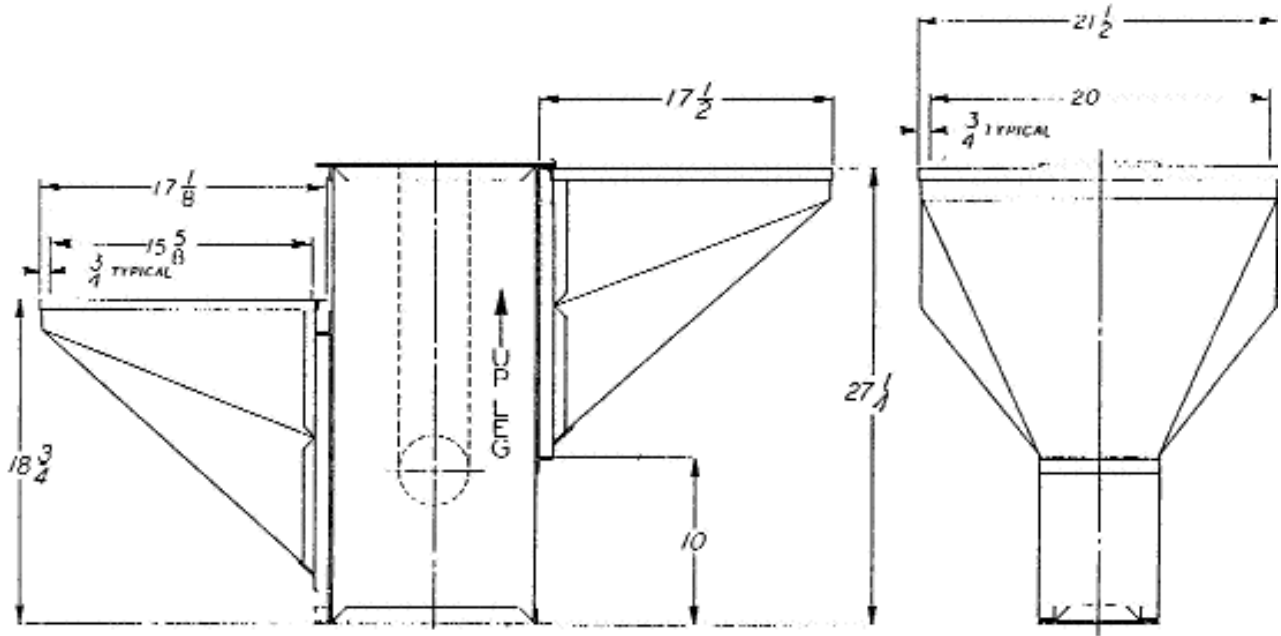

**SPOUT HOPPER**

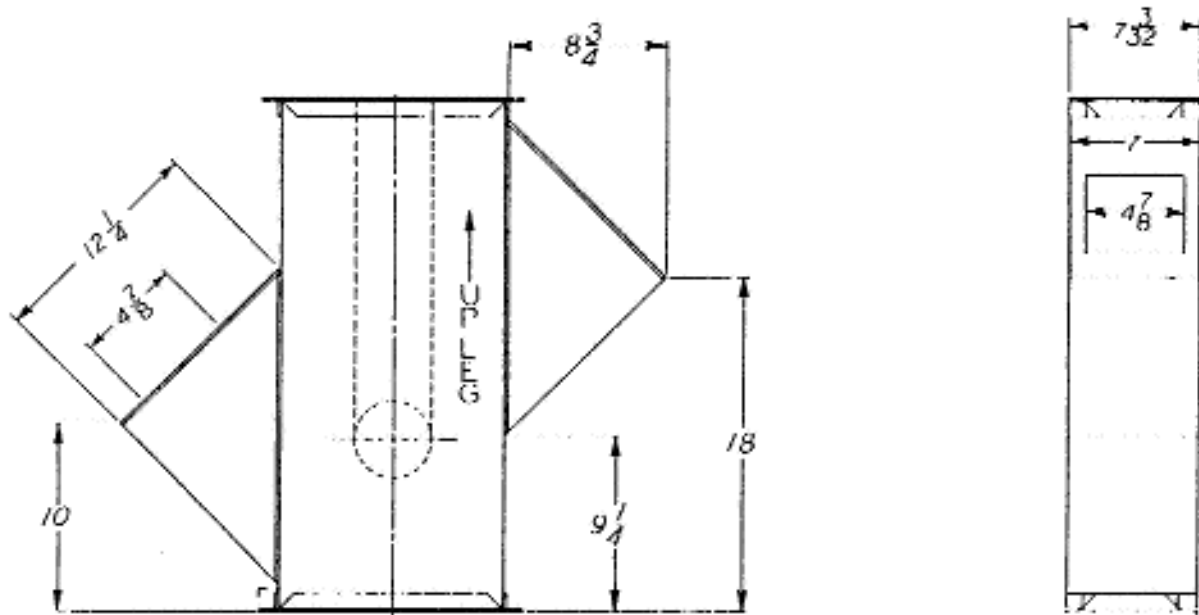

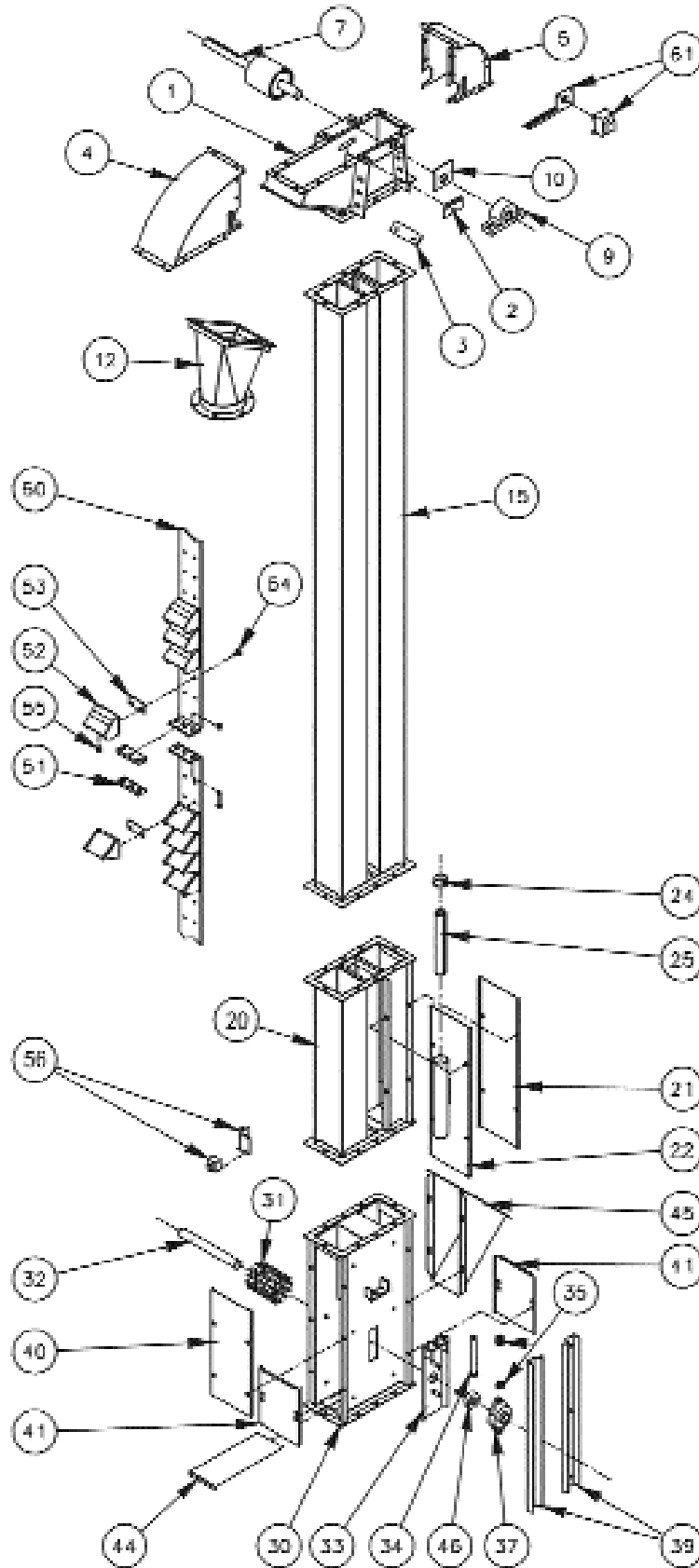

# SECTION 11

# PARTS LIST

INDEX NO.	PART NO.	DESCRIPTION	QTY.
<b>B3 ELEVATOR HEAD COMPONENTS (INDEX NUMBERS 1 THROUGH 12)</b>			
1	32016	CASING,HEAD,LOWER,B3/U,CS	1
2	30332	COVER,INSPECTION,HEAD,GS	2
3	30455	DEFLECTOR,DL,B3/U,BLK	1
4	32061	CASING,HEAD,DL,B3/U,CS	1
5	32046	CASING,HEAD,UL,B3/U,CS	1
7.1	32398	PULLEY&SHAFT,ASSY,B3/U,#1,CS,1.19X13.75,BLK,LAG	AR
7.2	32407	PULLEY&SHAFT,ASSY,B3,#1,CS,BS,1.19X15.50,BLK,LAG	AR
7.3	32400	PULLEY&SHAFT,ASSY,B3/U,#2,CS,1.19X17.25,BLK,LAG	AR
7.4	32404	PULLEY&SHAFT,ASSY,B3/U,#4,CS,1.19=>1.00X17.25,BLK,LAG	AR
7.5	35931	PULLEY&SHAFT,ASSY,B3,#4,CS,BS,1.19=>1.00X17.25,BLK,LAG	AR
9.1	35026	BRG,1.188,2BPP,LOCKING-COLLAR	2
9.2	53050	BRG,1.188,2BPP,LOCKING-COLLAR,IPTCI	1
10	30331	SEAL,HEADSHAFT,B3,1.188,UHMW	2
12	32219	DISCHARGE_SPOUT,B3/U,CS	1
15.1	32171	TRUNK,6.00,B3,CS	AR
15.2	32170	TRUNK,12.00,B3,CS	AR
15.3	32169	TRUNK,24.00,B3,CS	AR
15.4	32168	TRUNK,36.00,B3,CS	AR
15.5	32167	TRUNK,48.00,B3,CS	AR
15.6	32166	TRUNK,60.00,B3,CS	AR
15.7	43336	TRUNK,72.00,B3,CS	AR
15.8	39787	TRUNK,84.00,B3,CS	AR
15.9	32165	TRUNK,96.00,B3,CS	AR
20A	32135	ACCESS,COMPLETE,W/COVER,B3,CS	1
20	32132	CASING,ACCESS,ASSY,B3,CS	1
21	32129	COVER,ACCESS,B3,CS	1
22	32162	COVER,ASSY,ACCESS,W/TUBE,B3,CS	1
24	30466	CAP,TAPERED,INST.TUBE	2
25	41941	MANUAL.SERVICE.B3	1
<b>B3 ELEVATOR BOOT COMPONENTS (INDEX NUMBERS 30 THROUGH 46)</b>			
30	32114	CASING,BOOT,ASSY,B3,CS	1
31	34709	PULLEY,BOOT,SPOKE,1.19,B3/U,CI	1
32	32113	SHAFT,BOOT,1.19X10.50,B3/U,CS	1
33	30339	SLIDE,ASSY,BOOT,B3/C3,GS	2
34	35614	BOLT,HH-TAP,0.625-11X6.00,ZP,GR2	2
35	30156	NUT,HEX,0.625,ZP	6
37.1	53049	BRG,1.188,2BFL,LOCKING-COLLAR,IPTCI	2
37.2	35035	BRG,1.188,2BFL,LOCKING-COLLAR	2
39	30356	GUIDE,TU,B3/C3,CS	4
40	32107	COVER,BOOT,DL,B3,CS	1
41	32110	COVER,BOOT,REMOVABLE,B3,CS	2
44	32105	SLIDE,CLEANOUT,BOOT,B3,GS	1
45	32294	HOPPER,SPOUT,ASSY,B3/U,CS	1
46	30427	SEAL,FOAM,2.13ODX1.00ID	2
50	-----	SEE PAGE 11-6 FOR BELT OPTIONS	AR
51	35267	CLAMP,BELT,KIT,B3/U,CS	1
52.1	30445	BKT,HDPE,4.00X3.00	AR
52.2	35922	BKT,HDPE,4.00X3.00,VNT	AR
52.3	45668	BKT,NYLON,4.00X3.00,UI	AR
52.4	46287	BKT,URETHANE,4.00X3.00,UI	AR
52.5	32330	BKT,CS,3.75X3.00,18GA	AR
52.6	32342	BKT,CS,3.75X3.00,18GA,VNT	AR
52.7	32338	BKT,CS,3.75X3.00,14GA	AR
52.8	32334	BKT,SS,3.75X3.00,18GA	AR
52.9	35192	BKT,SS,3.75X3.00,18GA,VNT	AR
53	30488	CUSHION,BUCKET,BLK,B3/U	AR
54	30510	BOLT,EB,0.250-20X1.00X0.812HD	AR
55	30151	NUT,HEXFLANGE,0.250-20,ZP	AR
60&61	39816	SWITCH,DISCONNECT&SHUTOFF (ELEVATOR SAFETY SWITCH PKG)	1
	30410	SCREW,HHCS,0.312-18X0.75,ZP	AR
	30655	NUT,HEX,0.312-18,ZO	AR

LEGEND:

CS = CARBON STEEL	GS = GALVANIZED STEEL	DL = DOWN-LEG	UL = UP-LEG	BRG = BEARING
2BPP = 2 BOLT PILLOW BLOCK	CI = CAST IRON	ZP = ZINC PLATED	TU = TAKE-UP	GR = GRADE
OD = OUTSIDE DIAMETER	ID = INSIDE DIAMETER	2BFL = 2 BOLT FLANGE	BKT = BUCKET	HDPE = PLASTIC
VNT = VENTED	SS = STAINLESS STEEL	EB = ELEVATOR BOLT	UHMW = ULTRA HIGH MOLECULAR WEIGHT	
HHCS = HEX HEAD CAP SCREW	GA = GAUGE	BLK = BLACK	HD = HEAD DIAMETER	PKG = PACKAGE

## MODEL B3 - BELT - BUCKETS - BOLTS - CUSHIONS - WASHERS

NOTE: If the added extension will place your elevator in a belt category requiring stronger belt, the entire belt should be replaced. As speed is increased or buckets are added check the drive requirements.

BELT LENGTH FORMULA:  $2 \times DH + 3'$

BUCKET FORMULA:  $7.4 \times DH + 7$

LEGGING FORMULA:  $DH \text{ MINUS } 4'$

BELT		
PART NO.	DESCRIPTION	QUANTITY
34900	BELT,4",UNI-PLY,120,BLK,180F	PER FOOT
34901	BELT,4",UNI-STOCK R,BLK,212F	PER FOOT
34904	BELT,4",PVK,120,WHT,180F	PER FOOT
34903	BELT,4",LO-TEMP,150,BLK,TO-40F (HARSH WEATHER)	PER FOOT
FOR ADDITIONAL BELT OPTIONS AND SPECIFICATIONS, SEE ELEVATOR BELT IN ELEVATOR ACCESSORIES SECTION		

BUCKETS		
PART NO.	DESCRIPTION	QUANTITY
30445	BKT,HDPE,4.00X3.00	AR
35922	BKT,HDPE,4.00X3.00,VNT	AR
45668	BKT,NYLON,4.00X3.00,UI	AR
46287	BKT,URETHANE,4.00X3.00,UI	AR
32330	BKT,CS,3.75X3.00,18GA	AR
32342	BKT,CS,3.75X3.00,18GA,VNT	AR
32338	BKT,CS,3.75X3.00,14GA	AR
32334	BKT,SS,3.75X3.00,18GA	AR
35192	BKT,SS,3.75X3.00,18GA,VNT	AR

BOLTS - CUSHIONS - WASHERS		
PART NO.	DESCRIPTION	QUANTITY
30510	BOLT,EB,0.250-20X1.00X0.812HD	AR
30711	BOLT,EB,0.250-20X1.25X0.812HD	AR
30151	NUT,HEXFLANGE,0.250-20,ZP	AR
30712	BOLT,EB,0.250-20X1.00X0.812HD,SS18-8	AR
30645	NUT,HEXFLANGE,0.250-20,SS	AR
30488	CUSHION,BUCKET,BLK,B3/U	AR
30489	CUSHION,BUCKET,WHT,B3/U	AR
31719	WASHER,RUBBER,1.00X0.312ODX0.125	AR
FOR ADDITIONAL OPTIONS AND SPECIFICATIONS, PLEASE CONSULT FACTORY		

**LEGEND:**

BLK = BLACK	F = FAHRENHEIT	WHT = WHITE	BKT = BUCKET	CS = CARBON STEEL
SS = STAINLESS STEEL	GA = GAUGE	VNT = VENTED	EB = ELEVATOR BOLT	HD = HEAD DIAMETER



# SECTION 11

# OPTIONAL EQUIPMENT

INTAKE ACCESSORIES	
PART NO.	DESCRIPTION
32306	HOPPER,SPOUT,KIT,B3/U,CS
32645	HOPPER,DUMP,KIT,B3/U,CS
32491	HOPPER,DUMP,BAG BREAKER & SCREEN,KIT,B3/U,CS
42834	HOPPER,SPOUT,NARROW,B3,CS
32309	COVER,HOPPER,SPOUT,B3/U,CS
32262	COVER,DUMP,B3/U,GS
	ALLOWANCE FOR (32306) HOPPER,SPOUT - WITH UNIT ORDER (32645) HOPPER,DUMP IN LIEU OF (32306) HOPPER,SPOUT - WITH UNIT ORDER (32491) HOPPER,DUMP,BB&SCRN IN LIEU OF (32306) HOPPER,SPOUT - WITH UNIT ORDER

DISCHARGE ACCESSORIES	
PART NO.	DESCRIPTION
33164	VALVE,ASSY,8",3WAY,MANUAL,CS (VALVE BODY ONLY)
32658	VALVE,ASSY,8",2WAY,MANUAL,CS (VALVE BODY ONLY)
32711	VALVE,ASSY,8",OFFSET,MANUAL,CS (VALVE BODY ONLY)
32219	DISCHARGE,SPOUT,B3/U,CS
32374	ADAPTOR,VALVE,ASSY,B3/U,CS
33140	ADAPTOR,FLATTOP,8"SQUAREX6"ROUND,CS
32748	ADAPTOR,SQUARE2ROUND,8"X6",CS
32503	ADAPTOR,SQUARE2ROUND,8"X8",CS
	ALLOWANCE FOR (32219) DISCHARGE,SPOUT

NOTE: For more discharge options see Miscellaneous Accessories under Elevator Accessories in the catalog.

**FOR USE WITH VALVES:**

- 1) WITHOUT DISCHARGE SPOUT: NEED (1) (32374) ADAPTOR,VALVE WITH DISCHARGE SPOUT: NEED (1) (33140) ADAPTOR,FLATTOP
- 2) IF ROUND OUTLETS ARE DESIRED, ADD ON CORRECT NUMBER OF DESIRED SQUARE TO ROUND OUTLETS.

CLEANOUT ACCESSORIES	
PART NO.	DESCRIPTION
32515	BOOT,EXTENSION,KIT,B3/U,CS (4" LEGS FOR BOTTOM OF BOOT)
32344	CLEANOUT,ABC,KIT,B3/U,CS,SH (FOR SPOUT HOPPER)
40542	CLEANOUT,ABC,KIT,B3,CS,DH (FOR DUMP HOPPER)
32486	CLEANOUT,HDC,KIT,B3/U,CS,SH (FOR SPOUT HOPPER)
39770	CLEANOUT,HDC,KIT,B3/U,CS,DH (FOR DUMP HOPPER)
30349	CLEANOUT,AVC,KIT,B3/U,CS,AC
30077	CLEANOUT,AVC,KIT,B3/U,CS,DC

SERVICE ACCESSORIES	
PART NO.	DESCRIPTION
32514	CAGE,FLARED,SAFETY,KIT (3' FLARED ENTRY)
	SERVICE LADDER, PER FOOT DISCHARGE HEIGHT MINUS 4'
	SAFETY CAGE, PER FOOT
	WEATHER & DUST SEALING, BASE PRICE (LEGGING ONLY)
	- ADD PER FOOT OF DISCHARGE HEIGHT
35695	ADHESIVE,DOC-700-INDUSTRIAL-GR,S-CLEAR,10.3-OZ VENT OPENING IN HEAD (TO RECEIVE 4" PIPE)

SENSOR ACCESSORIES	
PART NO.	DESCRIPTION
43516	SWITCH,M800,UNDERSPEED,110VAC,50/60HZ
43517	SWITCH,M800,UNDERSPEED,24VDC
43518	SWITCH,M800,UNDERSPEED,220VAC,50/60HZ
43519	WHIRLIGIG,SENSOR,MOUNT,WG1-4B

**LEGEND:**

CS = CARBON STEEL	GS = GALVANIZED STEEL	ABC = AUTOMATIC BOOT CLEANOUT	HDC = HINGED DOOR CLEANOUT
DH = DUMP HOPPER	SH = SPOUT HOPPER	AVC = AIR VACUUM CLEANOUT	AC = ALTERNATE CURRENT
DC = DIRECT CURRENT	VAC = VOLT ALTERNATE CURRENT	VDC = VOLT DIRECT CURRENT	HZ = HERTZ

# SECTION 11

# OPTIONAL DRIVE PACKAGING

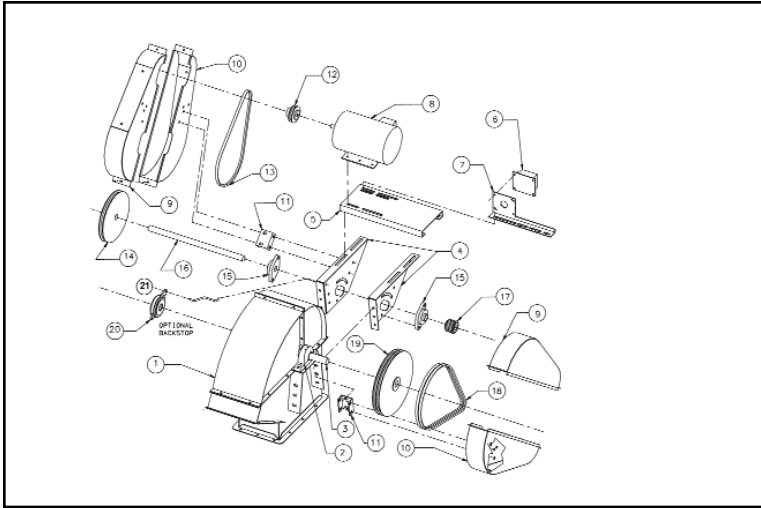

## #1 DRIVE PACKAGE

(INCLUDES V-BELTS, SHEAVES,  
MOTOR MOUNT & GUARDS)

SEE PAGE 11-9 FOR PARTS

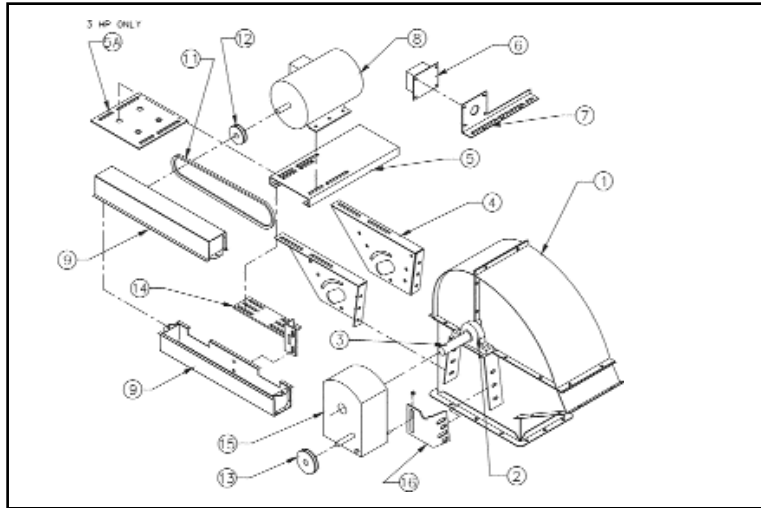

## #2 DRIVE PACKAGE

(INCLUDES V-BELTS, SHEAVES,  
REDUCER, MOTOR MOUNT &  
GUARDS)

SEE PAGE 11-10 FOR PARTS

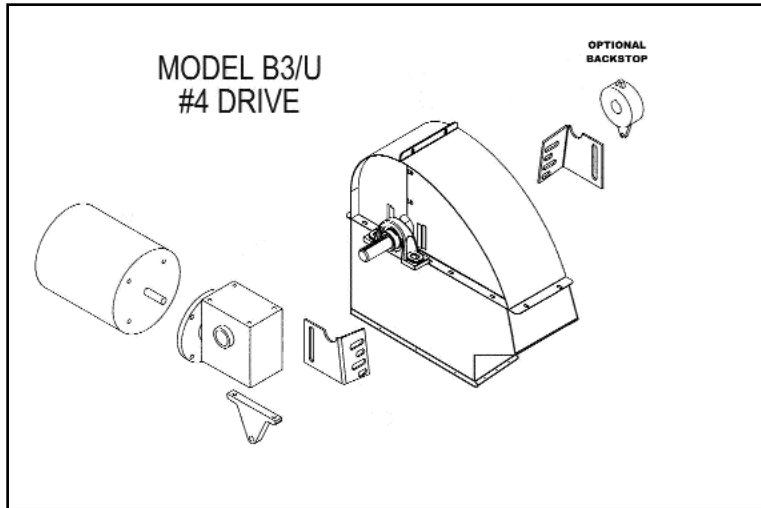

MODEL B3/U  
#4 DRIVE

## #4 DRIVE PACKAGE

SHAFT MOUNT WORMGEAR W/3PH  
TEFC MOTOR

<u>RPM</u>	<u>HP (MAX)</u>
86	3/4
115	1
173	1
230	1 1/2

SEE PAGE 11-11 FOR PARTS

SPECIFICATIONS SUBJECT TO CHANGE WITHOUT NOTICE

# SECTION 11

# #1 DRIVE PARTS LIST

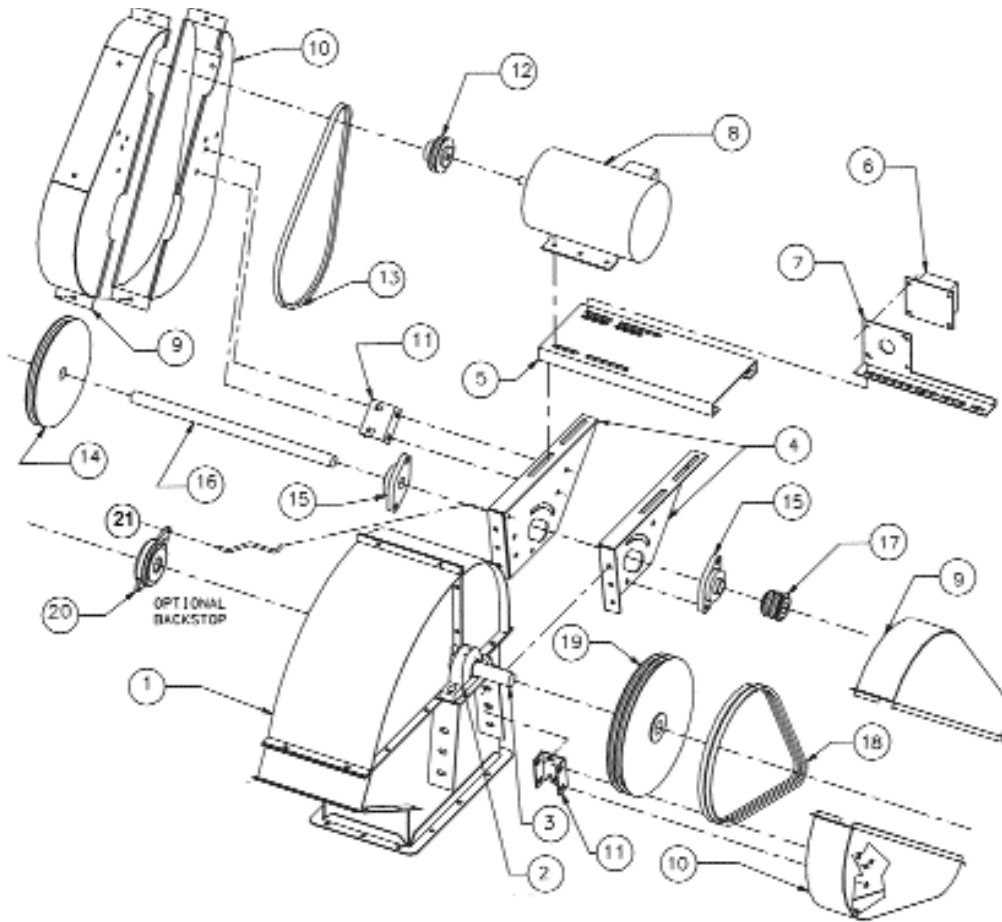

INDEX NO.	PART NO.	DESCRIPTION	QTY.
1	-----	HEAD ASSEMBLY **	1
2.1	53058	BRG,1.00,2BFL,CS,SET-SCREW,IPTCI	AR
2.2	35026	BRG,1.188,2BPB,LOCKING-COLLAR (STANDARD B3 ELEVATOR)	AR
2.3	35031	BRG,1.188,2BPB,TYPE-E (STANDARD U ELEVATOR)	AR
3.1	32398	PULLEY&SHAFT,ASSY,B3/U,#1,CS,1.19X13.75,BLK,LAG	1
3.2	32407	PULLEY&SHAFT,ASSY,B3/#1,CS,BS,1.19X15.50,BLK,LAG	1
4.1	31488	BRKT,MOTORMOUNT,B3/C3,LH,GS	1
4.2	33400	BRKT,MOTORMOUNT,B3/C3,RH,GS	1
5	31489	PLATE,MOTOR,MOUNT,B3/C3,GS	1
6&7	39816	SWITCH,DISCONNECT&SHUTOFF (ELEVATOR SAFETY SWITCH PKG)	1
8	-----	MOTOR (SEE ELECTRIC MOTOR PRICE LIST IN ELEVATOR ACCESSORIES SECTION)	1
9	31493	GUARD,DRIVE,B3/C3,#1,OUTSET,CS	2
10	31494	GUARD,DRIVE,B3/C3,#1,INSET,CS	2
11	31490	BRKT,DRIVEGUARD,B3/C3,#1,CS	2
12	-----	SHEAVE (MOTOR) **	1
13	-----	V-BELT(S) **	AR
14	-----	SHEAVE (COUNTERSHAFT - 1ST STAGE) **	1
15	35024	BRG,1.00,2BFL	2
16	31491	SHAFT,COUNTER,B3,CS	1
17	-----	SHEAVE (COUNTERSHAFT - 2ND STAGE) **	1
18	-----	V-BELT(S) **	AR
19	-----	SHEAVE (HEADSHAFT) **	1
20	36193	BACKSTOP,EXTERNAL,RACH-ARM-ASSY (NEEDED: #32407)	1
21	31498	BRKT,TORQUE,B3/C3/#2/#4,CS	1

\*\*CONSULT FACTORY WITH MODEL OF ELEVATOR

LEGEND:

BRG = BEARING	2BPB = 2 BOLT PILLOW BLOCK	CS = CARBON STEEL	BRKT = BRACKET	LH = LEFT HAND
RH = RIGHT HAND	GS = GALVANIZED STEEL	PKG = PACKAGE	2BFL = 2 BOLT FLANGE	

SPECIFICATIONS SUBJECT TO CHANGE WITHOUT NOTICE

# SECTION 11

# #2 DRIVE PARTS LIST

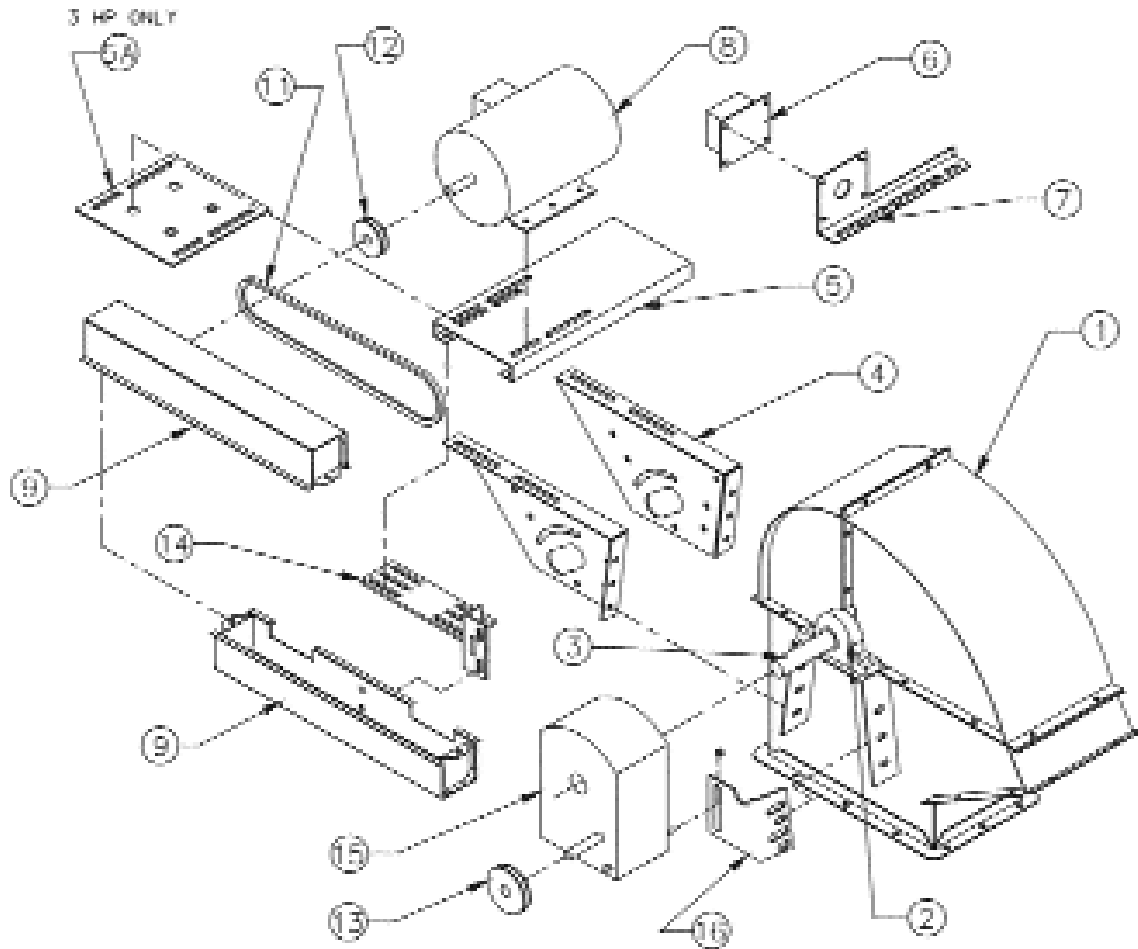

INDEX NO.	PART NO.	DESCRIPTION	QTY.
1	-----	HEAD ASSEMBLY **	1
2.1	35026	BRG,1.188,2BPB,LOCKING-COLLAR (FOR USE WITH B3 ELEVATOR)	AR
2.2	35031	BRG,1.188,2BPB,TYPE-E (FOR USE WITH U ELEVATOR)	AR
3	32400	PULLEY&SHAFT,ASSY,B3,#2,CS,1.19X17.25,BLK,LAG	1
4.1	31488	BRKT,MOTORMOUNT,B3/C3,LH,GS	1
4.2	33400	BRKT,MOTORMOUNT,B3/C3,RH,GS	1
5	31489	PLATE,MOTOR,MOUNT,B3/C3,GS	1
6&7	39816	SWITCH,DISCONNECT&SHUTOFF (ELEVATOR SAFETY SWITCH PKG)	1
8	-----	MOTOR (SEE ELECTRIC MOTOR PRICE LIST IN ELEVATOR ACCESSORIES SECTION)	1
9	32000	GUARD,DRIVE,B3/C3,#2,GS	2
11	-----	V-BELT(S) **	AR
12	-----	SHEAVE (Motor) **	1
13	-----	SHEAVE (Reducer) **	1
14	32007	BRKT,ASSY,DRIVEGUARD,C3,#2,CS	1
15	-----	REDUCER **	1
16	31498	BRKT,TORQUE,B3/C3,#2,CS	1

\*\*CONSULT FACTORY WITH MODEL OF ELEVATOR

LEGEND:

BRG = BEARING	2BPB = 2 BOLT PILLOW BLOCK	CS = CARBON STEEL	BRKT = BRACKET
LH = LEFT HAND	RH = RIGHT HAND	GS = GALVANIZED STEEL	PKG = PACKAGE

## SECTION 11

## #4 DRIVE PARTS LIST

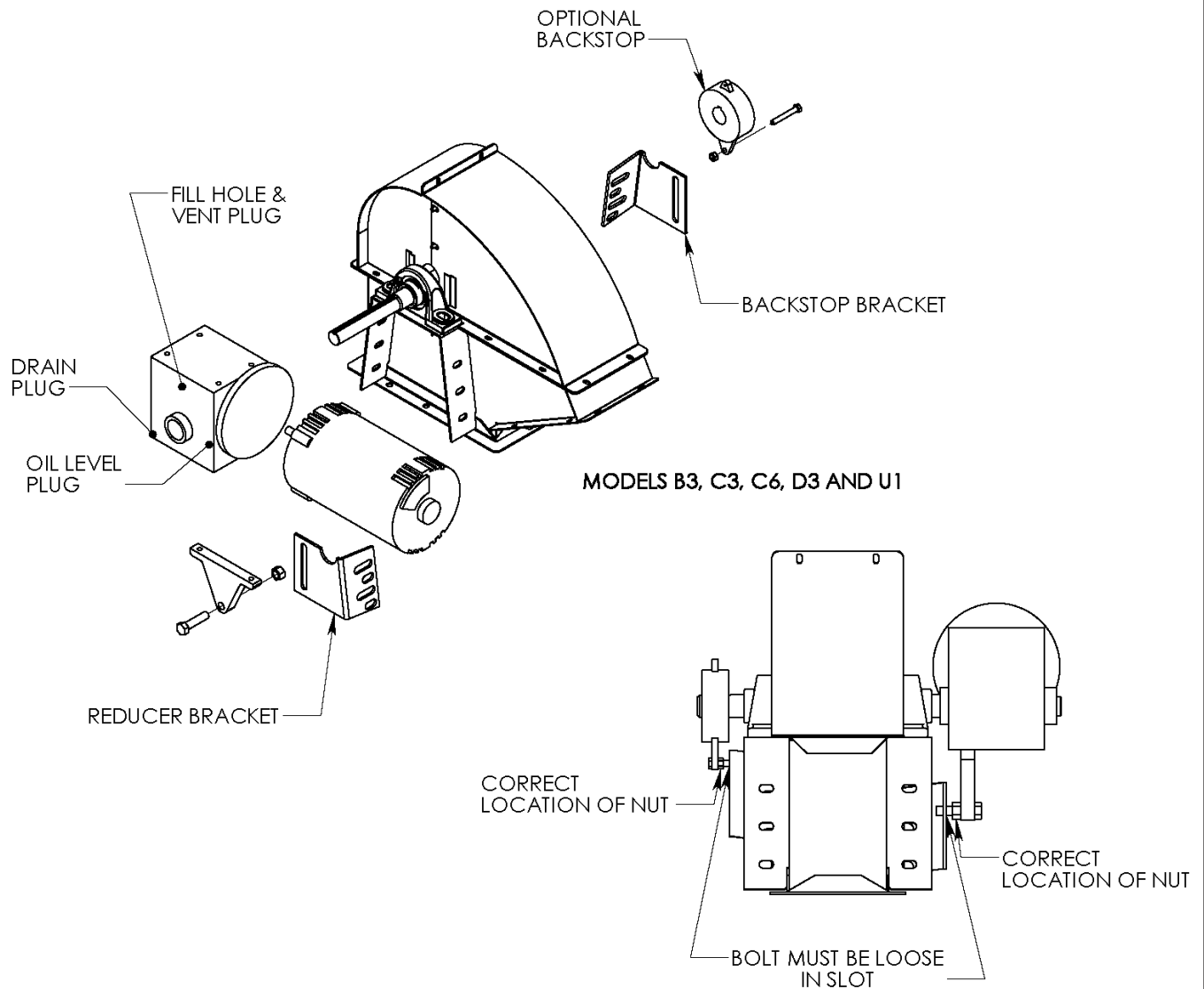

DO NOT INSTALL NUT ON BACKSIDE OF REDUCER BRACKET! YOU MAY CREATE A SIDE LOAD THAT WILL CAUSE PREMATURE WEAR ON THE REDUCER LEADING TO FAILURE.

DO NOT INSTALL NUT ON BACKSIDE OF BACKSTOP BRACKET! YOU MAY CREATE A SIDE LOAD THAT WILL CAUSE PREMATURE WEAR ON THE BACKSTOP LEADING TO FAILURE.

SEALS SHOULD BE ROUTINELY CHECKED FOR LEAKS AND WEAR. IF LEAKS ARE FOUND, CHECK THE OIL LEVEL OF THE REDUCER. IF OIL LEVEL IS LOW, (REFER TO REDUCER VENT AND LEVEL POSITION CHART PROVIDED WITH UNIT), ADD PROPER LUBRICATION THROUGH THE FILLER PLUG UNTIL IT COMES OUT THE OIL LEVEL PLUG.

INSPECT VENT PLUG OFTEN TO INSURE IT IS CLEAN AND OPERATING.

DO NOT ALLOW DIRT OR DUST TO BUILD UP ON REDUCER AS IT MAY CAUSE THE UNIT TO OVER HEAT.

**SECTION 11**

**LOCKABLE DISCONNECT SWITCH**

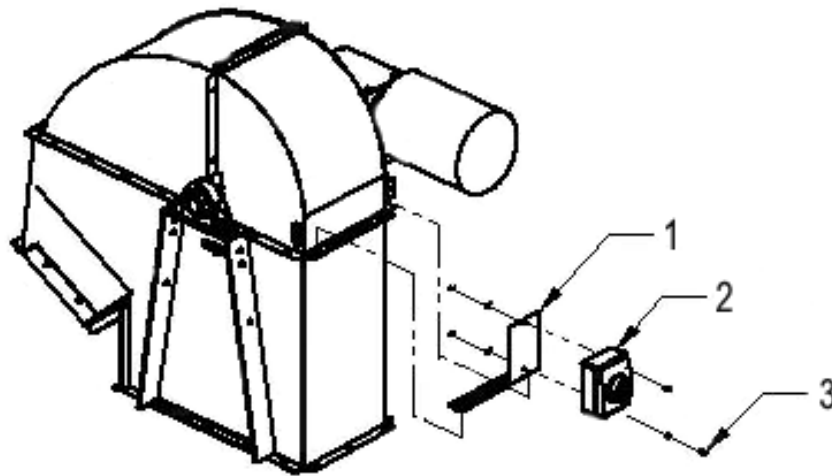
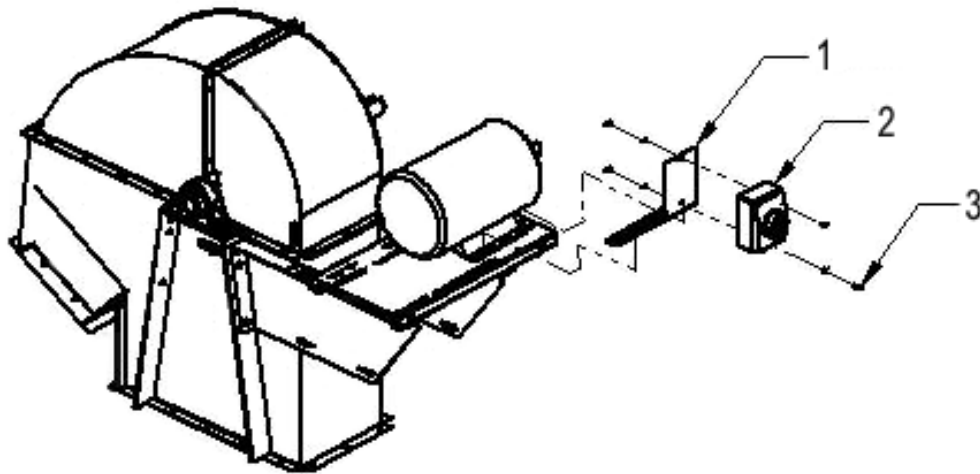

Item #	Description	Part #	Quantity
1	Bracket	30348	1
2	Lockable Disconnect Switch	47700	1
3	Machine Screw, #8-32 x 3/4	30406	1
	Flatwasher	30417	2
	Hex Nut	30424	1

**SAFETY INSTRUCTIONS**

THE OPERATOR IS REQUIRED TO READ AND FOLLOW ALL SAFETY INSTRUCTIONS AND WARNINGS ON THIS MACHINE. ADDITIONAL SAFETY INSTRUCTIONS ARE LOCATED IN PLACES:

1. SAFETY INSTRUCTIONS PROVIDED WITH THE MACHINE.
2. SAFETY INSTRUCTIONS PROVIDED WITH THE MACHINE.
3. SAFETY INSTRUCTIONS PROVIDED WITH THE MACHINE.
4. SAFETY INSTRUCTIONS PROVIDED WITH THE MACHINE.
5. SAFETY INSTRUCTIONS PROVIDED WITH THE MACHINE.

SEE THE OPERATOR'S MANUAL FOR MORE INFORMATION ON SAFETY INSTRUCTIONS AND WARNINGS.

SEE THE OPERATOR'S MANUAL FOR MORE INFORMATION ON SAFETY INSTRUCTIONS AND WARNINGS.

SEE THE OPERATOR'S MANUAL FOR MORE INFORMATION ON SAFETY INSTRUCTIONS AND WARNINGS.

A. 30139

**WARNING**

DO NOT STEP ON OR CROSS OVER THIS CONVEYOR WHEN IT IS RUNNING OR STOPPED. CROSS ONLY AT WALKWAYS PROVIDED. FAILURE TO FOLLOW THIS WARNING MAY CAUSE SERIOUS INJURY OR DEATH.

B. 30137

**DANGER**

DO NOT REMOVE ANY PROTECTIVE COVER OR GUARD WHILE THE MACHINE IS RUNNING OR STOPPED. FAILURE TO FOLLOW THIS WARNING MAY CAUSE SERIOUS INJURY OR DEATH.

C. 30140

**DANGER**

**PINCH POINT**

BE VERY CAREFUL IN THIS AREA WHERE MOVING PARTS OF THE MACHINE MEET. FAILURE TO FOLLOW THIS WARNING MAY CAUSE SERIOUS INJURY OR DEATH.

E. 30128

**WARNING**

**ADJUSTABLE OVERLOAD CLUTCH UNDER THIS COVER.**

MAY HAVE HOT SURFACES. LOCKOUT POWER BEFORE SERVICING OR ADJUSTING.

THIS UNIT - LOADED OR EMPTY - EVEN WITH POWER OFF - COULD RUN FORWARD OR BACKWARD IF CLUTCH IS LOOSE. ALWAYS KEEP OTHER PERSONS AWAY FROM ENTIRE MACHINE WHEN SERVICING THE CLUTCH. FAILURE TO DO SO COULD CAUSE SEVERE INJURY OR DEATH.

D. 30141

**SAFETY INSTRUCTION**

**PULL CORD TO STOP CONVEYOR**

F. 41809

**WARNING**

THIS UNIT WILL START AUTOMATICALLY WITHOUT WARNING. DISCONNECT AND LOCK OFF POWER BEFORE CLEANING OR SERVICING.

G. 30132

**WARNING**

LOCK POWER OFF BEFORE CLEANING OR SERVICING THIS MACHINE. FAILURE TO DO SO MAY RESULT IN SERIOUS INJURY OR DEATH.

H. 30131

**WARNING**

DO NOT STEP ON OR CROSS OVER THIS CONVEYOR WHEN IT IS RUNNING OR STOPPED. CROSS ONLY AT WALKWAYS PROVIDED. FAILURE TO FOLLOW THIS WARNING MAY CAUSE SERIOUS INJURY OR DEATH.

J. 30143

**Universal Industries**

Model: \_\_\_\_\_  
 Lot: \_\_\_\_\_  
 Date: \_\_\_\_\_

UNIVERSAL INDUSTRIES  
 1000 W. 10th St., Des Moines, IA 50319  
 (515) 281-1111

G. 30132

**WARNING**

REMOVING OR OPENING THIS COVER WILL EXPOSE MACHINE PARTS THAT CAN CAUSE SERIOUS INJURY OR DEATH. LOCK POWER OFF. ONLY TRAINED PERSONS USING EXTREME CAUTION SHOULD EVER CLEAN, REPAIR OR ADJUST THIS MACHINE WITH COVERS REMOVED. REPLACE COVERS AND GUARDS BEFORE USING THIS MACHINE.

K. 30129

**WARNING**

**KEEP OFF**

THIS IS NOT A STEP COVER IS TO PREVENT ACCIDENTAL CONTACT WITH ELEVATOR CURS. REPLACE COVER AFTER EACH USE.

L. 30144

**WARNING**

BEFORE SERVICING THIS UNIT, LOCK OFF POWER AND DISCONNECT THE POWER SOURCE. FAILURE TO FOLLOW THIS WARNING MAY CAUSE SERIOUS INJURY OR DEATH.

S. 30146

**SAFETY, INSTALLATION, AND MAINTENANCE MANUAL**

SEE THE OPERATOR'S MANUAL FOR MORE INFORMATION ON SAFETY INSTRUCTIONS AND WARNINGS.

P. 30134

**PLEASE CHECK!**

BEFORE SERVICING THIS UNIT, LOCK OFF POWER AND DISCONNECT THE POWER SOURCE. FAILURE TO FOLLOW THIS WARNING MAY CAUSE SERIOUS INJURY OR DEATH.

T. 30130

**UNIVERSAL**

M. 30133

**UNIVERSAL**

N. 30145

SECTION 11

DECAL PARTS LIST

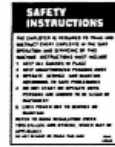

A. 30139



B. 30137



C. 30140



E. 30128



D. 30141



F. 41809



G. 30132



M. 30133



H. 30131



J. 30143



G. 30132



K. 30129



L. 30144

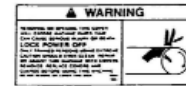

S. 30146

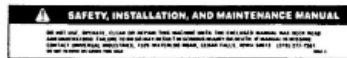

P. 30134



N. 30145



T. 30130

DRAWING SYMBOL	PART NUMBER	DESCRIPTION	QTY.
A	30139	Decal,Safety Instruction	1
B	30137	Decal,Hopper Warning Sign	2
C	30140	Decal,Danger Sign	1
D	30141	Decal,Adjustable Clutch Sign	0
E	30128	Decal,Pinch Point Sign	1
F	41809	Decal,Safety,Instruction,Conv	0
G	30132	Decal,Auto Start Warning	0
H	30131	Decal,Disconnect/Lockout Sign	1
J	30143	Decal,Crossover	0
K	30129	Decal,Access&CVR Warning Sign	2
L	30144	Decal,Hopper Cover Warning Sign	1
M	30133	Decal,Vertical Universal Sign	2
N	30145	Decal,Horizontal,3.00X14.50 (Universal)	0
P	30134	Decal,Installation Maintenance (Manual Holder Sign)	1
R	30135	Decal,Identification Sign	1
S	30146	Decal,Drive Guard Warning	1
T	30130	Decal, Please Check Setscrew	2



## SECTION 12

## SOURCES OF STANDARDS AND CODES

The Company expects the customer/owner of supplied equipment to comply with all applicable safety code standards, and good practices. Below is a list of organizations that publish various standards that may apply to your machine. This list is included for your convenience, does not necessarily contain all codes and standards, and is to be periodically updated by you.

Universal recommends that owners and operators make an effort to keep themselves informed on the topic of safety. Standards are constantly evolving and it requires vigilance to remain fully informed.

**Here is a list of some of the various standards that are categorized by subject of concern:**

<b>Safety Concern</b>	<b>Organization and Publication Section</b>
Altering Safety Characteristics	ANSI B20.1 paragraph 5-12.7
Backstops, Brakes	ANSI B20.1 paragraph 5.05
Cages (for ladders)	OSHA 1910.24d, 2, 5
Drive Guards	OSHA 1910.219m; 217c2b
Electrical	NEC; OSHA 1910.300
Emergency Stop Switches	ANSI B20.1 paragraph 5-11.2c
Ladders	OSHA 1910.24b
Lock Out Hazardous Energy Sources	OSHA 1910.147
Platforms	OSHA 1910.23c3; 23e; 24b
Point of Operation	OSHA 1910.212a3; 217c2b; ANSI B20.1 paragraph 5.09.1.1
Guards and Covers	
Shafting, shaft ends, couplings, guards	OSHA 1910.219; .219c4; .219l
Inlet Grates	OSHA 1910.272j
Interfacing Machines	ANSI B20.1 paragraph 5-11c

For additional copies: write Universal Industries, Inc. • PO Box 308 • Cedar Falls, IA 50613

### Addresses of some of the various societies publishing rules, regulations and recommended practices:

American Society of Agricultural Engineers (ASAE)  
2950 Niles Road  
St. Joseph, MI 10018

American National Standards Institute (ANSI)  
25 West 43rd Street, 4th Floor  
New York, NY 10036  
Phone: (212) 642-4900

National Fire Protection Association (NFPA)  
(Publisher of the National Electrical Code)(NEC)  
P.O. Box 9101  
Quincy, Massachusetts 02269-9101  
Phone: (800) 344-3555

American Society of Mechanical Engineers (ASME)  
345 East 47th Street  
New York, NY 10017

U.S. Department of Agriculture (USDA)  
14th Street and Independence Avenue, S.W.  
Washington, DC 20250

Factory Mutual Engr. Corp. (FM)  
P. O. Box 9102  
Norwood, MA 02062  
Phone: (781) 440-8000

Society of Automotive Engineers (SAE)  
400 Commonwealth Drive  
Warrenberg, PA 15096

Underwriters Laboratories (UL)  
207 East Ohio Street  
Chicago, IL 60611

American Society for Testing and Materials (ASTM)  
100 Barr Harbor Drive  
West Conshohocken, PA 19428-2959  
Phone: (610) 832-9585

OSHA, Office of Mechanical Engineering Safety Standards, Room N  
3621 OSHA Dept. of Labor  
200 Constitution N.W.  
Washington, DC 20210



Air Cleanout Operation .....	9-1
AVC-Air Cleanout Operation .....	9-1
AVC Assembly .....	9-4
AVC Parts Diagram.....	9-5
AVC Parts List.....	9-6
Backstops .....	8-2
Bar Clamp .....	8-2
Bearing Lubrication .....	8-2
Belt Splice & Bucket Installation .....	7-1
Belt,Buckets & Accessories .....	11-7
Bolt & Set Torque Values .....	8-4
Boot Adjustments .....	9-3
Bucket Spacing .....	7-1
Decals, Diagram.....	11-13
Decals, Parts List .....	11-14
Dimension Drawing .....	11-2
Disclaimer for Misuse .....	3-1
Electrical Shock Hazards .....	5-1
Elevator Installation.....	6-1
General Installation .....	4-1
General Operation .....	8-1
General Safety Practices .....	2-2
General Specifications .....	11-1
Hoppers.....	11-3
Installations - Electrical .....	5-0
Installations - General.....	4-0
Installer Checklist.....	6-2
Lockable Disconnect Switch .....	11-12
Lubrication Instructions .....	8-3
Maintenance .....	8-1
Mistracking.....	7-2
Motor Rotation Check.....	4-1
Open System Elevators .....	2-2
Operation & Maintenance .....	8-1
Operator Injury .....	5-1
Optional Drive Packages .....	11-8
Optional Equipment.....	11-7
Parts Diagram, B3.....	11-4
Parts Diagram, Decals .....	11-13
Parts Diagram, AVC .....	9-5
Parts Diagram, Lockable Disconnect Switch .....	11-12
Parts List, AVC.....	9-6
Parts List, B3.....	11-5
Parts List, Decals .....	11-14
Parts List, #1 Drive.....	11-9
Parts List, #2 Drive.....	11-10
Parts List, #3 Drive.....	11-11
Periodic Inspections.....	8-1
Personnel Check Off Form .....	13-1
Problem Diagnosis.....	10-1
Product Safety Statement.....	2-1
Protection From Short Circuits.....	5-1
Receiving .....	3-1

Safety .....	2-1
Safety Alert Symbols.....	2-1
Setscrew Tightness.....	8-3
Slight Current Excesses .....	5-1
Sources of Standards & Codes .....	12-1
Specifications .....	11-1
Start-Up & Empty Run-In Period.....	7-2
Terms and Conditions of Sale.....	1-1
Troubleshooting .....	10-1
Universal Machine Identification .....	Front Cover
Vacuum Cleaning Operation.....	9-2
Walkway Construction Over Machine.....	2-3

# TOC

## TABLE OF CONTENTS

Description	Page
<b>Universal Machine Identification</b> .....	Front Cover
<b>Section 1: Terms and Conditions of Sale &amp; Warranty</b> .....	1-1
<b>Section 2: Safety Section</b>	
Product Safety Statement .....	2-1
Safety Alert Symbols .....	2-2
Open System Elevators .....	2-3
Walkway Construction Over Machine .....	2-3
<b>Section 3: Receiving</b> .....	3-1
<b>Section 4: Installation - General: Motor Rotation Check</b> .....	4-1
<b>Section 5: Installation - Electrical</b>	
Operator Injury .....	5-1
Electrical Shock Hazards .....	5-1
Protection from Short Circuits .....	5-1
Slight Current Excesses .....	5-1
Emergency Shut-off Switches .....	5-2
<b>Section 6: Elevator Installation</b>	
Method A .....	6-1
Method B .....	6-1
Method C .....	6-1
For All Methods .....	6-2
Installer Checklist .....	6-2
<b>Section 7: Belt Splice &amp; Bucket Installation</b>	
Bucket Spacing .....	7-1
Installing the Bar Clamp Belt Splice .....	7-1
Mistracking .....	7-2
Start-Up & Empty Run Period .....	7-2
<b>Section 8: Operation &amp; Maintenance</b>	
General .....	8-1
Periodic Inspections .....	8-1
Backstops .....	8-1
Operating Suggestions .....	8-2
Bearing Lubrication .....	8-2
Lubrication Instructions .....	8-3
Bearing Lubrication Guide .....	8-3
Set Screw Tightness .....	8-3
Bolt & Setscrew Torque Values .....	8-4



Universal Industries, Inc.

5800 Nordic Drive • P.O. Box 308 • Cedar Falls, IA 50613-0308  
Phone: (319) 277-7501 • Fax: (319) 277-2318

# TOC

## TABLE OF CONTENTS

### **Section 9: AVC-Air Cleanout Operation, Optional Equipment**

AVC Operation .....	9-1
Air Cycling AVC Operation .....	9-1
Vacuum Cleanout Operation.....	9-2
Boot Adjustments .....	9-3
Removing of Existing Parts.....	9-3
Modification to Existing Boot.....	9-3
Attaching/Assembling of the Air Vacuum Clean-out Equipment.....	9-4
Parts Diagram .....	9-5
Parts List .....	9-6

<b>Section 10: Problem Diagnosis:Troubleshooting .....</b>	<b>10-1</b>
--	-------------

### **Section 11: General Specifications**

Specifications .....	11-1
Dimensional Drawing .....	11-2
Parts Diagram .....	11-3
Parts List .....	11-4
Optional Equipment.....	11-5
Belt, Buckets & Accessories .....	11-5
Parts List #2 Drive.....	11-6
Hinged Boot Cleanout.....	11-7
Parts Diagram, Lockable Disconnect Switch .....	11-8
Parts Diagram, Decals .....	11-9
Parts List, Decals .....	11-10

<b>Section 12: Sources of Standards &amp; Codes.....</b>	<b>12-1</b>
--	-------------

<b>Section 13: Personnel Check Off Form .....</b>	<b>13-1</b>
---	-------------

<b>Index.....</b>	<b>14-1</b>
-------------------	-------------



Universal Industries, Inc.

5800 Nordic Drive • P.O. Box 308 • Cedar Falls, IA 50613-0308  
Phone: (319) 277-7501 • Fax: (319) 277-2318