



Universal Industries

MPC CONVEYOR



Manual

P/N 48724

Safety, Installation, Maintenance,
Operation & Parts

Model: _____

For Parts or Service Contact:

S.N.: _____

Universal Industries, Inc.

Date: _____

5800 Nordic Drive • P.O. Box 308 • Cedar Falls, IA 50613-0019
Phone: (319) 277-7501 • Fax: (319) 277-2318

TOC

TABLE OF CONTENTS

Description	Page
Universal Machine Identification	Front Cover
Terms and Conditions of Sale	1-1
Safety Section	
Product Safety Statement	2-1
Safety Alert Symbols.....	2-2
General Safety Practices	2-3
Disclaimer for Misuse	3-1
Receiving	4-1
Installation & Initial Operation	5-1
Maintenance	
General Maintenance.....	6-1
Periodic Inspections.....	6-1
Bearing Lubrication.....	6-1
Reducer & Motor Lubrication	6-2
Idler Lubrication	6-2
Operation	
Loading the Belt.....	7-1
Unloading the Belt	7-1
Operating the Belt.....	7-1
General Specifications	
General Specifications	8-1
Parts List & Diagram.....	8-2
Parts Diagram-Lockable Disconnect Switch.....	8-3
Parts Diagram-Decals.....	8-4
Parts List-Decals.....	8-5
Sources of Standards & Codes	9-1
Personnel Check Off Form	10-1
Index	11-1



Universal Industries, Inc.

5800 Nordic Drive • P.O. Box 308 • Cedar Falls, IA 50613-0308

Phone: (319) 277-7501 • Fax: (319) 277-2318

TERMS AND CONDITIONS OF SALE

1. **TERMS OF PAYMENT:** Buyer agrees to pay the purchase price shown on the acknowledged Sales Order in accordance with the terms of payment stated on the Sales Order. Amounts not paid when due shall accrue interest at the rate of 1.5% per month from the due date. For all sales on open account, the full purchase price shall be due 30 days from the date of the Invoice. However, Seller reserves the right to require down payment and/or progress payments, which shall be specified on the Sales Order. Unless otherwise specified, all sales are exclusive of freight, taxes, and other amounts due third parties. Discounts for early payment shall be as stated on the Invoice. Discounts shall not apply to the amount of any freight, taxes of other sums due any third party. Terms begin on the date of the Invoice. Seller shall establish the credit terms available to Buyer based on a current credit application and any other information available to Seller. At any time, Seller may limit or cancel the amount or time of credit extended to Buyer, in the sole opinion of Seller. Buyer shall pay in cash before delivery (C.O.D) for any order or part of an order in excess of the approved credit terms of Buyer. In the event Buyer fails to pay in advance any amount demanded by Seller, Seller shall have the right, in addition to any other remedies available, to cancel the contract or sell all or any part of the undelivered goods without notice at public or private sale, holding Buyer responsible for any deficiency.

2. **SECURITY INTEREST:** Seller reserves and Buyer hereby grants to Seller a security interest in the goods shipped under this agreement and the proceeds derived from their sale of whatever nature, whether in cash, note or account. This security interest shall continue until the full purchase price and any related expenses and/or charges due in connection with the Sales Order are paid in full. Notes shall not be considered as payment buy merely as evidence of indebtedness. Seller shall be entitled to all the rights of a secured party under Iowa law. Buyer agrees to execute any documents required to perfect or confirm this security interest.

3. **TITLE/RISK OF LOSS:** Title to all goods priced at shipping point shall pass to Buyer upon delivery at such shipping point. All risk of loss shall be Buyer's from the time of shipment. Seller's responsibility for any loss or damage to the goods ceases at the time delivery is made to the carrier. Buyer shall be solely responsible for making any claim(s) against the carrier for any loss or damage.

4. **EXPORT ORDERS:** Prices for export-crating charges can be obtained by contacting the Sales Department for quotations and orders.

5. **PRICE CHANGES:** The prices listed may be changed by Seller without notice in order to reflect Seller's prices at time of shipment and any increase in transportation, labor or other costs. If a delivered price has been quoted, any charges at destination for spotting, switching, handling, storage, and other accessorial services and demurrage shall be borne by Buyer. Seller reserves the right to correct any obvious errors or mistakes in specifications or prices.

6. **WHEN ORDERING:** Please specify name of item, catalog part number, as well as other information when this is applicable to insure prompt handling of the order.

7. **MINIMUM BILLING:** \$50.00 Net, exclusive of transportation charges.

8. **DELIVERIES:** Any delivery schedule indicated is based on Seller's present estimate of the time required to ship after receipt of Buyer's order. In the event of any delay in Seller's performance due in whole or in part to any cause beyond Seller's reasonable control, Seller shall have such additional time for its performance as may be reasonably necessary under the circumstance.

9. **MANUALS:** Seller will furnish one combined safety, installation, operation, maintenance, and parts manual. Extra manuals will be sent on request.

10. **SHIPMENT:** Shipment may be by carrier or other means selected by Seller. All units are shipped-knocked down. If shipment is delayed by Buyer, date of readiness for shipment shall be deemed to be date of shipment for payment purposes. If manufacture is delayed by Buyer, a payment shall be made based on purchase price and percentage of completion, balance payable in accordance with the terms as stated. Equipment held for Buyer shall be at the risk and expense of Buyer.

11. **LIMITED WARRANTY:** Seller warrants that the components and parts that it manufactures for its machines and equipment will be free from defects in material or workmanship for a period of one (1) year from the date of shipment by Seller. Seller does not warrant any component or part not manufactured by Seller. If, during the one year warranty period, Buyer discovers a defect in material or workmanship of a covered component, Buyer shall promptly (and in no event later than thirteen (13) months after the date of shipment by Seller) notify Seller in writing of such defect. Within a reasonable time of receiving such notification, Seller will furnish a replacement component or part. Buyer shall be responsible for all expenses attendant to the shipment and installation of the replacement component or part. Buyer also shall be responsible for returning the defective component or part to Seller if request by Seller to do so. **THE FOREGOING WARRANTY IS IN LIEU OF ALL OTHER WARRANTIES, EXPRESSED OR IMPLIED, SELLER DISCLAIMS THE IMPLIED WARRANTY OR MERCHANTABILITY AND ANY IMPLIED WARRANTY OF FITNESS FOR A PARTICULAR PURPOSE.**

SELLER SPECIFICALLY DOES NOT WARRANT PARTS AND COMPONENTS PURCHASED BY SELLER FROM THIRD PARTY SUPPLIERS, INCLUDING, BUT NOT LIMITED TO, SUCH PARTS AND COMPONENTS AS MOTORS, BEARINGS, REDUCERS, AND SWITCHES. BUYER SHALL BE LIMITED IN RECOURSE FOR SUCH COMPONENTS AND PARTS TO THE TERMS OF THE WARRANTY OF THAT PARTICULAR MANUFACTURER.

12. **LIMITATION OF REMEDIES AND DAMAGES:** Buyer's primary remedy for breach of warranty is the provision of a replacement component or part, as stated above. If Seller is unable to provide a replacement component or part, Buyer's alternate remedy shall be refund of Buyer's purchase price. These remedies are Buyer's sole and exclusive remedies for breach of warranty. In no event shall Seller be liable under any theory of liability for (i) damages in excess of Buyer's purchase price or (ii) any special, incidental or consequential damages.

13. **TIME TO BRING SUIT:** Buyer shall bring any action relating to the goods sold by Seller pursuant to his Sales Order or Invoice, including any action for breach of contract or breach of warranty, not later than two (2) years after the date of shipment by Seller. Buyer agrees that any action brought after such date shall be barred as being untimely.

14. **PLACE OF BRINGING SUIT:** Any action relating to the goods sold by Seller pursuant to this Sales Order or Invoice shall be brought in the Iowa District Court in and for Black Hawk County, Iowa.

15. TOLERANCES AND VARIATIONS: All goods shall be subject to tolerances and variations consistent with usual trade practices regarding dimension, straightness, section, composition and mechanical properties and normal variations in surface and internal conditions and quality and shall also be subject to deviations from tolerances and variations consistent with practical testing and inspection methods.

16. RETURNS: Returns are not accepted unless Seller is first notified of the reason for the return, and has granted permission for the return to be made. A return authorization tag will be issued on agreed-to returns. Credit for permitted returns will not exceed the price charged when shipment was made, or the market price at the time the return was received. 20% handling charge will be made on all returned goods. In case of damaged goods, the charge will rise accordingly. When the cause for return is due to incorrect shipment by Seller, there will be no restocking or freight charge. Any merchandise that is to be returned must be received with a return authorization tag attached and freight charges-Prepaid. Any returns authorized by Seller are conditioned upon the goods being returned in condition for resale.

17. COPYRIGHT: No reproduction either in whole or in part may be made from Seller's catalog, drawings, sketched, etc., without written permission from Seller's Sales Department.

18. BACK ORDERS: Seller will attempt to ship all orders complete; however, in the event of back orders, the orders will be shipped with freight charges, collect or prepaid, at Seller's option only.

19. SHORTAGES: Claims for shipping shortages concealed or otherwise, will not be allowed by Seller, unless reported within 15 days after date of shipment by Seller.

20. PRODUCT CHANGES: Seller reserves the right to change, without notice, the design or any modular, "standardized" components represented in Seller's catalog.

21. TOOLS, DIES AND FIXTURES: Unless otherwise expressly provided herein, any tools, dies, or fixtures which may be developed for Seller in the production of the goods covered hereby shall be owned by Seller, as Seller may elect, even though Buyer is charged in whole or in part for the cost of such tools, dies and fixtures.

22. PATENT INFRINGEMENT: If any of the goods are to be furnished to Buyer's specification, Buyer agrees to indemnify Seller and Seller's successors and assigns, against all liabilities and expenses resulting from any claim of infringement of any patent in connection with the production of such goods.

23. SPECIAL DRAWING OR DATE REQUIREMENTS: Seller will provide, upon request, an 8 ½ x 11 copy of any line drawing shown in the catalog without charge. Seller reserves the right to reject any request and/or assess a charge for any other drawing.

24. CANCELLATION: Except as otherwise provided in Paragraph 1, order may be cancelled or modified only by written agreement between the parties. On specially ordered or fabricated equipment, no cancellation will be allowed. Buyer's insistence upon cancelling or suspending fabrication or shipment, or Buyer's failure to furnish specifications when required, may be treated by Seller as a breach of contract by Buyer, and Seller may cancel any unshipped balance without prejudice to any other remedies Seller may have.

25. TAXES: All applicable federal, state or local sales, use, occupational or excise taxes are the responsibility of the Buyer and shall be in addition to the price or prices stated unless otherwise specifically stated. Seller shall have the right to Invoice separately any such tax as may be imposed at a later time. Applicable tax exemption certificates must accompany any order to which the same applies.

26. MODIFICATIONS OF ALTERATIONS TO EQUIPMENT: Seller shall not be liable for any product that is modified or altered by Buyer or it's assignee or successor regardless of whether Seller knows or is aware of such modification or alteration.

27. EQUIPMENT OPERATION: Buyer agrees to require its employees to read and be familiar with the safety instructions and the operation and maintenance portion of the manual before operating this equipment. Buyer agrees to require its employees to use all safety devices and guards on the equipment and to use safe operating procedures. Buyer agrees to not remove or modify any such equipment, switch, device, guard or warning sign. If Buyer, or its employees, fail to strictly observe all of these obligations, Buyer agrees to indemnify and save Seller harmless from any liability or obligation incurred by Seller to persons injured directly or indirectly by the operation of the equipment.

28. RESALE, TRANSFER, OR LEASE OF EQUIPMENT TO OTHERS: Buyer agrees to the continuing obligation to notify Seller of the resale, transfer or lease of the equipment to third parties, stating the name and address of the new owner or transferee and the location of the equipment.

29. REPORTING PERSONAL INJURIES OR PROPERTY DAMAGE: The Buyer or user agrees to notify Seller within 30 days of any accident or occurrence involving Seller's machinery or equipment resulting in personal injury or property damage, and shall cooperate fully with Seller in investigating and determining the cause of such accident or occurrence. In the event that the Buyer or user fails to give such notice to Seller and so cooperate, the Buyer or user agrees to indemnify and save Seller harmless from all loss or damage arising from such accident or occurrence.

30. ASSIGNABILITY: Any contract for sale and purchase of machinery and equipment cannot be assigned except with the written consent of Seller.

31. SUCCESSOR OWNERS AND USERS: The terms and conditions hereof are binding on successor owners and users, who take by purchase, assignment, lease, or otherwise, the right to own, use or operate the equipment sold to the original Buyer, and said terms and conditions shall transfer with the equipment itself as an integral obligation of any successor to the original Buyer. The successor owner and user obligations and liabilities stated herein shall also apply if the original Buyer was a dealer and purchased the equipment from Seller for purposes of resale and transfer to third parties.

32. ENTIRE AGREEMENT: These Terms and Conditions of Sale constitute the entire agreement between the parties concerning any machinery or equipment sold and purchased. It shall not be modified or cancelled except by mutual agreement in writing signed by all parties.

33. APPLICABLE LAW: The laws of the state of Iowa shall govern and control the rights, duties, remedies, and obligations of Seller, Buyer, successors, user, and owner and Iowa law shall be used to interpret and construe all of the terms and conditions hereof.

PRODUCT SAFETY STATEMENT

UNIVERSAL INDUSTRIES, INC. PRODUCT SAFETY STATEMENT

To: Customers, Dealers, Owners, and Users

Universal Industries, Inc. strives to make its products safe. However, because of the wide variety of applications for its products, often Universal does not know how the equipment is being used and installed. Consequently, Universal cannot directly control the installation of its product to assure compliance with applicable safety codes and practices. Nevertheless, Universal has listed various safety codes, standards, and regulations in its Manuals to assist the owner-user in providing a safe installation.

Universal will continue its best efforts to design, build, and market a safe product, and will continue to advocate and urge a safe installation of that product.

Universal requests your written suggestions as to how its product could be manufactured to improve its safety, convenience of use, function, repair, and maintenance. Written suggestions should be dated, signed, and mailed to:

Product Safety and Planning
Universal Industries, Inc.
P.O. Box 308
Cedar Falls, Iowa 50613

SAFETY ALERT SYMBOLS



This is a **safety alert symbol** and is used in this manual and on signs placed on the machine to call attention to specific safety precautions.

The following words are **signal words**. Signal words have specific meaning when used with this symbol.

CAUTION

Denotes a general reminder of good safety practices or to direct attention to unsafe practices which, could result in personal injury if proper precautions are not taken.

WARNING

Denotes specific potential hazard, which can result in injury or death if proper precautions are not taken.

DANGER

Denotes the most serious specific potential hazard, which would result in high probability of death or irreparable injury if proper precautions are not taken.

All machines have inherent hazards such as moving parts, energy (electrical, mechanical or hydraulic), sharp edges and fumes or dust. Personnel must keep clear of moving machinery. Only authorized and trained persons are to be involved in the operation of this machine. **Any disregard for instructions and safety precautions can cause serious injury or death.**

Guards, disconnects, lock-outs and other features are provided or are available to improve operator safety.

This machine must not be altered in any manner or operated with any damage, missing, or malfunctioning parts. If modification is deemed necessary to accomplish the user's requirements, write or FAX a description including a sketch or drawing to the Company with identification, condition and any previous modifications. The company may be able to help the customer avoid creating a hazardous situation. Careful attention must be given to adjacent machinery and accessible space for cleaning and inspection. Other factors should be planned for such as: product spillage, dust pollution, personnel space, interfacing of machines, automatic startup, and handling of hot materials.

GENERAL SAFETY PRACTICES

- ◆ Instruct all operators in the safe use of the unit. This will vary from installation to installation. Instruction should consist of a thorough understanding of all Operation and Maintenance instructions in the following sections, these General Safety Practices, and other instructions as your particular installation may require.
- ◆ Only qualified and trained persons should operate and/or perform maintenance work on the unit.
- ◆ Always have drive guards installed and closed when unit is in operation.
- ◆ Make certain that unit is supported and/or guyed adequately for its height, span, size, load, etc.
- ◆ Repair or replace any weakened, damaged, or broken guys or structural supports before continuing operation.
- ◆ When installing unit, leave adequate room and clearances for the proper use of the unit, including the usual cleaning, servicing, and maintenance operations.
- ◆ All controls, switches, switch lock-outs, etc. should be specified, located, installed, and used in strict accordance with accepted safety standards and applicable codes, regulations and requirements.
- ◆ Except as otherwise required, this unit must be stopped and starting equipment locked out before making adjustments or doing maintenance work.
- ◆ Any adjustments or maintenance procedures that are required while the unit is in operation should be done only by qualified and trained persons who are aware of the danger of working around moving belts and parts. Such adjustments or maintenance should not be done without another person present to control the on-off switch.
- ◆ Guard rails or suitable enclosures should be built around the tail assembly of a conveyor if it is in an area where persons may walk around it while the conveyor is in operation.
- ◆ Warning decals are affixed to the unit in several locations. Since installations differ, however, an extra DANGER decal and an extra CAUTION decal are enclosed with these instructions for use in your particular installation. These extra decals should be affixed to the unit to give additional warning in those locations where prudence and common sense would indicate. Additional decals are also available upon request without charge.
- ◆ Always comply with all of your applicable local codes, regulations and requirements for the installation, maintenance, and use of the unit, its controls and power source. The codes, regulations and requirements are for the protection and safety of you and your employees.

DISCLAIMER FOR MISUSE

Universal Industries is concerned that the customer is satisfied with the MPC. However, conditions such as over-feeding, lack of maintenance, improper housekeeping, or evidence of careless installation should not be construed as a responsibility of Universal Industries.

Though this manual strives to be as complete as possible, it cannot absolve the customer of his/her responsibility for providing the knowledgeable personnel to erect, start and maintain the MPC.

Operators who use the MPC must demonstrate good housekeeping and be aware of the personal dangers involved with careless operation.

The environment in which the MPC operates, and the product the MPC is handling, should be conducive with the function of the machine.

WARNING

FAILURE TO HEED ABOVE SAFE PRACTICES COULD RESULT IN SEVERE INJURY OR DEATH.

RECEIVING

Upon receipt of the MPC, check for shipping damage and report missing or obviously damaged items immediately to the truck line or carrier concerned. Check the packing list, and the semi-exploded view to identify everything and verify that the shipment is complete. Check availability of electric supply voltage, phases and amperage for conveyor drive motor.

When unloading the MPC, use forklifts or cranes with special care, and watch for any damage from previous rough handling. Such damage must be reported within 30 days after shipment for Universal Industries to allow any claims.

Returned goods will not be accepted unless Universal has authorized the return. Universal Industries must be notified in advance for the reason for the return. A return authorization tag can then be issued which must be attached to any returned merchandise. Freight charges are to be prepaid.

The Standard Charge for the return of unused equipment is 20% of the list price. This is based on the manufacturer's average cost of refurbishing and restocking this equipment. In case of damaged goods, the charge would be raised accordingly.

When the cause of return is due to an incorrect shipment by the factory, there will be no restocking or freight charge.



WARNING

**READ THE SAFETY SECTION! FAILURE TO FOLLOW SAFETY MESSAGES
COULD RESULT IN SEVERE INJURY OR DEATH.**

INSTALLATION

1. Assemble frame, head and tail assemblies.
2. Provide supports at head, tail and at every frame splice.
3. Install idlers (troughers and returns) perpendicular to belt travel by using a framing square against frame side rails.
4. Install Drive - Check for correct rotation of reducers equipped with a backstop.
5. Install Belt - Thick cover up. The thick cover side carries the material.

Before start up, be sure belt is free to operate in the right direction, and that tools, bolts or other items are not in a position to damage the belt or injure personnel due to running conveyor. Make sure DRIVE GUARD is in place. Warn everyone that the conveyor is about to start. Remember that there is always a danger in getting too close to moving equipment.

INITIAL OPERATION

START UP:

At start up, be sure the motor isn't running in wrong direction, possibly against a "Backstop". "Jog" the conveyor on and off for only a few seconds at a time to observe belt training. In the case of a long conveyor or a remote starting location, two or more persons should observe both the head and tail. This is necessary in order to stop the conveyor quickly in the case of a malfunction.

TROUBLESHOOTING:

If the conveyor belt will not train properly but is well centered on the idlers and pulleys,

1. Is the frame reasonably straight and true?
2. Are the Troughing idlers and the return idlers assembled reasonably square across the frame? Check this with a framing square.
3. Tighten Tail Pulley only enough to remove most of the sag out of the belt between idlers while conveyor is under full load. Tension should be just enough to remove sag and prevent conveyor belt slippage over drive pulley under full load.
4. If belt does not properly center on head or Tail Pulley, try applying more tension on the side to which it runs to. In the case of the fixed head Pulley, if necessary, adjust the belt by adding shims under bearing on the side the belt runs to.
5. REMEMBER: The belt is the vital part of your conveyor, treat it carefully for maximum service. In order for the belt to stabilize its position on the pulleys, it may be necessary to operate the conveyor for two or more cycles of the belt. This is true after final adjustments are made and the danger of gross misalignment and consequent belt damage is past.
6. If the belt tends to drift to one side of the idlers (troughers or returns), advance that side of the idler (or idlers) until the condition is corrected.
7. An incorrect or damaged belt splice could cause the belt to track erratically. Check and correct if necessary.
8. Check hopper skirts for unequal drag on the sides of the conveyor belt.

OPERATION & MAINTENANCE

GENERAL

WARNING

LOCK POWER OFF before performing inspections and maintenance. When it is necessary to observe the conveyor while running, use utmost care in keeping clear of the machine. Keep other personnel away from the area and be sure that other electrically connected equipment is also isolated from harming personnel. Never service this machine while it is in use. Use a buddy system with another experienced person who also can lock out the disconnect with his/her personal padlock. Use failsafe methods of communication, whether it be visual, radio or shouted messages. Restore all covers and guards before returning unit to operation. Replace missing, damaged or painted over safety signs with new ones from the Universal Industries.

FAILURE TO FOLLOW THESE INSTRUCTIONS COULD RESULT IN SERIOUS INJURY OR DEATH.

General maintenance involves only close inspection with a good light, and periodic cleaning of the MPC to remove material, dust and grime. Check the reducer lubrication, as instructed by its manufacturer, and keep all bearings properly lubricated. Watch for unusual or excessive wear on belt.

Promptly remove any spillage of material under the feed area. Never overfill bin or other equipment with the MPC because overflow, clogging, and spillage can jam belt, causing expensive downtime and damage. Periodically examine your MPC for loose or missing bolts.

PERIODIC INSPECTION

1. Allow no material to build up on the pulley faces, idlers or belt. Inspect chutes, hopper seals, and belt scrapers or cleaners for proper functioning.
2. Inspect the condition of the conveyor belt carefully both sides. Watch for unusually frayed or worn edges. This may indicate that the belt is not tracking properly and is over to one side scraping on part of the framework. This may occur only when the belt is being loaded so it is advisable to inspect the conveyor carefully in its entirety while it is being used. (Improper loading may drive belt over sideways.)
3. Inspect the conveyor belt both top and bottom for continuous grooves or worn tracks. These might be a result of contact with an object in the path of the belt.

MAINTENANCE

BEARING LUBRICATION

The ball bearings used on the head and tail shafts are prelubricated at the factory. Lubricate at start-up and relubricate approximately every six months of operation or more often if exposed to extremely dusty conditions or 24 hour a day operation. Using a good grade of grease, add grease until a slight bleeding of grease is noticeable at the seals.

For general purpose applications, use a #2 consistency Lithium Base grease formulated from a high quality mineral oil with rust and oxidation inhibitors.

Examples:	Mobilith AW2	Texaco Premium RB
	Mobilux #2	Exxon Unirex N2
	Shell Alvania #2	Amoco Amolith 2
	Texaco Multifak #2	

The table below is a general guide for relubrication. When relubricating bearings, add grease slowly while shaft is rotating. When grease appears at the seal area, the bearing contains the correct amount of lubricant. Bearings should operate at temperatures less than 200° F (200° C) and should not exceed 225° F (107° C) for intermittent operation.

Operating Conditions	Bearing Temperatures	Grease Interval	Recommended Grease
Clean	32°F to 120°F 120°F to 150°F 150°F to 200°F	6 to 10 Months 1 to 3 Months 1 to 4 Weeks	Shell Alvania #2 Texaco Multifak #2 Mobil Mobilux #2
Dirty	32°F to 120°F 150°F to 200°F	1 to 4 Weeks Daily - 1 Week	
Moisture	32°F to 200°F	Daily - 1 Week	

MAINTENANCE

REDUCER AND MOTOR LUBRICATION

Lubricate reducer and motor according to manufacturers' recommendations. Be sure to note any unusual leakage from seals or motor or reducer. If leakage is severe, lubrication must be scheduled more often and eventually the unit will have to be removed and repaired. *Keep lubricants off the belt.*

IDLER LUBRICATION

The idlers, which have no provision for a grease fitting, are factory lubricated and need no further lubrication. A careful inspection is in order, however, to check for binding. With the power locked off, raise belt with one hand and turn the idler with other hand.

1. Does it turn as freely as the others do?
2. Does it appear to be leaking lubricant excessively?
3. Is it noisy? Clicking or rattling could mean a dry bearing and impending failure.
4. Is there a flat spot or shiny strip lengthwise across idler? It could mean the idler is not turning when the belt is passing over it.
5. Is there spilled material around the base of the idlers? This shortens the life of seals and bearings and should be kept cleaner.

Efforts to wipe up leaking or excessive grease will be generously rewarded in increased belt life and ease of housekeeping.



CAUTION

WIPING CLOTHS SHOULD NEVER BE USED NEAR ROTATING PARTS. TURN OFF CONVEYOR BEFORE WIPING UP DIRT AND GREASE.

LOADING THE BELT

1. Keep heavy loads of material off the belt at feed hoppers. For example, do not allow a long chute full of material to come to rest on the belt, nor should a bin or large hopper be allowed to open directly on to the belt without some kind of flow control device metering out the amount of material entering onto the belt. It is NOT GOOD PRACTICE TO USE YOUR CONVEYOR AS A METERING DEVICE. There are heavy-duty belt feeders designed for metering out materials from under bins. These feeders usually have variable speed, are limited in length and are extra heavy duty. Try to arrange incoming material chutes in such a way as to allow material to flow freely onto belt and in such a direction as to help the material achieve belt speed without undue tumbling or churning. Longer belt life will result from using only rubber or urethane hopper skirting material. Using fabric-reinforced material or belting causes abrasion damage.
2. Be sure two (2) idlers are installed under the belt loading area. These holes will need to be field drilled to accommodate inlet location. One idler should be located approximately 12" to 18" from centerline of inlet (2 to 3 feet apart.)
3. Do not allow material to fall long distance and thereby gain high speeds as they approach the belt. Undue belt wear and leakage around hopper seals may result.
4. Load the belt evenly, with no offset of material to one side of belt. This will aid improper belt tracking.



CAUTION

BEWARE OF THE HAZARDS OF LOOSE CLOTHING.

UNLOADING THE BELT

1. End discharge over the head pulley is rather simple, but reasonable attention is necessary to prevent bins and chutes from overflowing and plugging material backing up against the moving belt. This is particularly damaging to the belt if the material is lumpy or abrasive, such as gravel or rock.
2. Plows and Trippers must be carefully installed and periodically checked for adjustment. Small rocks or stray pieces of hardware may become lodged in the machinery and cut grooves in the belt. Worn or misadjusted plows can be extremely damaging to the top belt covers. Tripper pulleys should turn freely and the belt should track properly around them.

OPERATING THE BELT

1. Most conveyors can be stopped and started under full load. However, if stopping and starting occurs more than two to four times an hour the motor and drive belts may have to be over-sized.
2. Most inclined conveyors should be equipped with a backstop (usually installed inside the shaft mount reducer). This will prevent the loaded conveyor from running backward during a power outage or normal shut-off. On a long conveyor, loaded heavily, this could damage inlet hoppers, weather covers and belt covers as the belt may be forced against conveyor framework by overflowing material. Check your empty conveyors occasionally to see if the backstop works.
3. Long belts, exposed to high winds, and without the protection of weather covers, may turn over or be blown off idler and return rollers.
4. Belts exposed to cold temperatures may develop temporary flats or "sets" but should work out again after several revolutions.
5. Replacement belting should be as transversely flexible or "troughable" as that which was provided originally. Such belting should be rated (in the same belt width) for operation with 45° three-roll idlers. It should also be rated for the diameter of pulleys used, and for the amount of oil or other chemicals used in each particular installation.
6. Cleanliness can add to the life of belt, idlers, drive and framework. Check for and repair loose hardware, rusting conditions and any potentially unsafe situations in order to reduce your long-term costs.

SPECIFICATIONS

SPECIFICATIONS

Up to 3,750 ft³/h @200 FPM

Model	MPC-16	MPC-24
Capacity @ 200 FPM	2,000 ft ³ /h 57.7 m ³ /h	1,067 ft ³ /h 108.1 m ³ /h
Belt Speed	25-200 FPM*	
Bearings	Sealed Industrial Ball Bearings	
Head Pulley	4 1/2" diameter with vulcanized rubber lagging	
Headshaft	1" or 1 1/4" diameter	
Tail Pulley	4 1/4" Self Cleaning	
Length (minimum)	5' center to center	
Length (maximum)	30' center to center	
Depth of Conveyor	4 9/16"	
Depth of Trough	1 1/2"	
Frame Construction	12 gauge formed channel	
Trough Construction	16 gauge	
Drive (Optional)	Shaft mounted reducer or gear reducer w/ roller chain & sprockets	
Trough Formula	Shaft center minus 24"	
Belt Formula	2x shaft centers plus 18"	

PARTS DIAGRAM

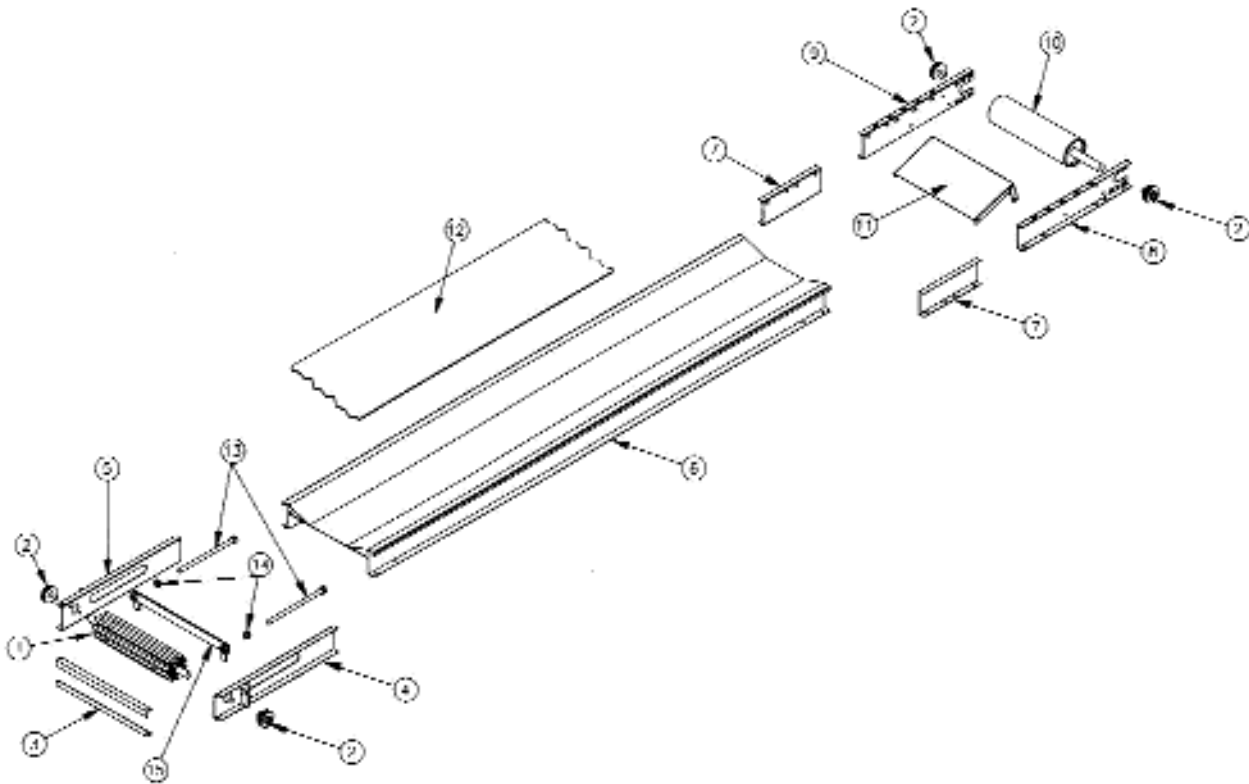

INDEX NO.	PART NO.	DESCRIPTION	QTY.
1.1	45334	PULLEY,SLATTED,TAIL,MPC10,CS	1
1.2	38650	PULLEY,SLATTED,TAIL,MPC16,CS	1
1.3	38659	PULLEY,SLATTED,TAIL,MPC24,CS	1
2.1	35020	BEARING,1.00,2BFL,SETSCREW	4
2.2	35023	BEARING,1.250,2BFL,W/45° ZERK	AR
3.1	45341	SPACER,TAIL,MPC10,CS	2
3.2	38635	SPACER,TAIL,MPC16,CS	2
3.3	38655	SPACER,TAIL,MPC24,CS	2
4	38641	SIDE,ASSY,TAIL,LH,MPC10/16/24,CS	1
5	38640	SIDE,ASSY,TAIL,LH,MPC10/16/24,CS	1
6	42773	TROUGH,ASSY,96.00,MPC10,CS	AR
6.2	38671	TROUGH,ASSY,96.00,MPC16,CS	AR
6.3	38924	TROUGH,ASSY,96.00,MPC24,CS	AR
7	38639	COUPLING,MPC10/16/24,CS	AR
8	38637	SIDE,ASSY,TAIL,LH,MPC10/16/24,CS	1
9	38636	SIDE,ASSY,TAIL,LH,MPC10/16/24,CS	1
10	39068	PULLEY&SHAFT,ASSY,MPC10,#4,CS1.00X19.44	AR
10.1	40988	PULLEY&SHAFT,ASSY,MPC16,#4,CS1.00X27.13	AR
10.2	43175	PULLEY&SHAFT,ASSY,MPC16,#4,CS1.25X28.00	AR
10.3	42113	PULLEY&SHAFT,ASSY,MPC24,#4,CS1.00X36.50	AR
10.4	42970	PULLEY&SHAFT,ASSY,MPC24,#4,CS1.00X37.00	AR
11		SPACER,HEAD,MPC10,CS	1
11.1	38638	SPACER,HEAD,MPC16,CS	1
11.2	38656	SPACER,HEAD,MPC24,CS	1
12		BELT	1
13	35613	BOLT,HH-TAP,ACME,0.625-8X,11.875,ZP	2
14	30668	NUT,HEX,0.625-8,ZP	2
15	45339	CROSSBAR,ASSY,TAIL,MPC10,CS	1
15.1	38647	CROSSBAR,ASSY,TAIL,MPC16,CS	1
15.2	38657	CROSSBAR,ASSY,TAIL,MPC24,CS	1

LOCKABLE DISCONNECT SWITCH

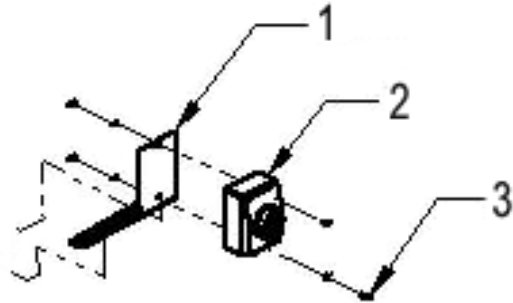

Item #	Description	Part #	Quantity
1	Bracket	30348	30348
2	Lockable Disconnect Switch	47700	47700
3	Machine Screw, #8-32 x 3/4	30406	30406
	Flatwasher	30417	30417
	Hex Nut	30424	30424

DECAL DIAGRAM

SAFETY INSTRUCTIONS

THE OPERATOR IS RESPONSIBLE FOR PROPER AND SAFE USE OF THIS EQUIPMENT. THE USER MUST READ AND UNDERSTAND ALL SAFETY INSTRUCTIONS AND OPERATING PROCEDURES OF THIS MACHINE. RESPECTFULLY MUST FOLLOW:

1. ALWAYS WEAR YOUR SAFETY BELT
2. ALWAYS WEAR YOUR SAFETY GLASSES
3. ALWAYS WEAR YOUR SAFETY SHOES
4. ALWAYS WEAR YOUR SAFETY GLOVES
5. ALWAYS WEAR YOUR SAFETY HELMET
6. ALWAYS WEAR YOUR SAFETY VEST
7. ALWAYS WEAR YOUR SAFETY CAP
8. ALWAYS WEAR YOUR SAFETY Goggles
9. ALWAYS WEAR YOUR SAFETY Goggles
10. ALWAYS WEAR YOUR SAFETY Goggles

A. 3040

WARNING

DO NOT STEP ON OR CROSS OVER THIS CONVEYOR WHEN IT IS RUNNING OR STOPPED. CROSSING AT WALKWAYS PROVIDED. FAILURE TO FOLLOW THIS WARNING MAY CAUSE SERIOUS INJURY OR DEATH.

B. 3041

WARNING

DO NOT STEP ON OR CROSS OVER THIS CONVEYOR WHEN IT IS RUNNING OR STOPPED. CROSSING AT WALKWAYS PROVIDED. FAILURE TO FOLLOW THIS WARNING MAY CAUSE SERIOUS INJURY OR DEATH.

H. 3047

WARNING

DO NOT STEP ON OR CROSS OVER THIS CONVEYOR WHEN IT IS RUNNING OR STOPPED. CROSSING AT WALKWAYS PROVIDED. FAILURE TO FOLLOW THIS WARNING MAY CAUSE SERIOUS INJURY OR DEATH.

M. 3050

K. 3049

UNIVERSAL

N. 3050.1

WARNING

DO NOT STEP ON OR CROSS OVER THIS CONVEYOR WHEN IT IS RUNNING OR STOPPED. CROSSING AT WALKWAYS PROVIDED. FAILURE TO FOLLOW THIS WARNING MAY CAUSE SERIOUS INJURY OR DEATH.

C. 3042

WARNING

ADJUSTABLE OVERLOAD CLUTCH UNDER THIS COVER.

MAY HAVE HOT SURFACES. LOCKOUT POWER BEFORE SERVICING OR ADJUSTING.

THIS UNIT - LOADED OR EMPTY - EVEN WITH POWER OFF - COULD RUM FORWARD OR BACKWARD IF CLUTCH IS LOOSE. ALWAYS KEEP OTHER PERSONS AWAY FROM ENTIRE MACHINE WHEN SERVICING THE CLUTCH. FAILURE TO DO SO COULD CAUSE SEVERE INJURY OR DEATH.

D. 3043

WARNING

DO NOT STEP ON OR CROSS OVER THIS CONVEYOR WHEN IT IS RUNNING OR STOPPED. CROSSING AT WALKWAYS PROVIDED. FAILURE TO FOLLOW THIS WARNING MAY CAUSE SERIOUS INJURY OR DEATH.

J. 3048

WARNING

KEEP OFF

THIS IS NOT A STEP. COVER HAS TOP PROTECTIVE ACCIDENTAL CONTACT WITH ELEVATOR CUPS. REPLACE COVER AFTER EACH USE.

L. 3049.5

SAFETY, INSTALLATION, AND MAINTENANCE MANUAL

DO NOT USE OPERATE, CLEAN OR REPAIR THIS MACHINE UNTIL THE ENCLOSED MANUAL HAS BEEN READ AND UNDERSTOOD. FAILURE TO DO SO MAY RESULT IN SERIOUS INJURY OR DEATH. IF MANUAL IS MISSING, CONTACT YOUR LOCAL DISTRIBUTOR, 1-800-368-8888, OR VISIT OUR WEBSITE, WWW.UNIVERSALINDUSTRIES.COM.

P. 3050.3

DANGER

PINCH POINT

BE VERY CAREFUL WITH THE ARM. WHEN THE ARM IS MOVING, LOCK OFF POWER BEHIND CLEANING OR SERVICING MACHINE. FAILURE TO FOLLOW THIS WARNING MAY CAUSE SERIOUS INJURY OR DEATH.

E. 3044

SAFETY INSTRUCTION

PULL CORD TO STOP CONVEYOR

DO NOT REMOVE OR COVER THIS CORD.

F. 3045

WARNING

THIS UNIT WILL START AUTOMATICALLY WITHOUT WARNING. DISCONNECT AND LOCK OFF POWER BEFORE CLEANING OR SERVICING.

G. 3046

Universal Industries

Division of Universal Industries, Inc. 10000 W. 10th Ave. Denver, CO 80202. Phone: 303.440.1111. Fax: 303.440.1112.

R. 3050.4

WARNING

DO NOT STEP ON OR CROSS OVER THIS CONVEYOR WHEN IT IS RUNNING OR STOPPED. CROSSING AT WALKWAYS PROVIDED. FAILURE TO FOLLOW THIS WARNING MAY CAUSE SERIOUS INJURY OR DEATH.

S. 3051

PLEASE CHECK!

A WARNING LABEL MUST BE PLACED ON THE MACHINE. FAILURE TO DO SO MAY RESULT IN SERIOUS INJURY OR DEATH. IF MANUAL IS MISSING, CONTACT YOUR LOCAL DISTRIBUTOR, 1-800-368-8888, OR VISIT OUR WEBSITE, WWW.UNIVERSALINDUSTRIES.COM.

T. 3086

DECAL PARTS LIST

DRAWING SYMBOL	PART NUMBER	DESCRIPTION	QTY.
A	30139	Decal,Safety Instruction	2
B	30137	Decal,Hopper Warning Sign	0
C	30140	Decal,Danger Sign	1
D	30141	Decal,Adjustable Clutch Sign	0
E	30128	Decal,Pinch Point Sign	1
F	41809	Decal,Safety,Instruction,Conv	0
G	30132	Decal,Auto Start Warning	4
H	30131	Decal,Disconnect/Lockout Sign	2
J	30143	Decal,Crossover	1
K	30129	Decal,Access&CVR Warning Sign	2
L	30144	Decal,Hopper Cover Warning Sign	0
M	30133	Decal,Vertical Universal Sign	2
N	30145	Decal,Horizontal,3.00X14.50 (Universal)	0
P	30134	Decal,Installation Maintenance (Manual Holder Sign)	1
R	30135	Decal,Identification Sign	1
S	30146	Decal,Drive Guard Warning	1
T	30130	Decal,Please Check Setscrew	8

SOURCES OF STANDARDS AND CODES

The Company expects the customer/owner of supplied equipment to comply with all applicable safety code standards, and good practices. Below is a list of organizations that publish various standards that may apply to your machine. This list is included for your convenience, does not necessarily contain all codes and standards, and is to be periodically updated by you.

Universal recommends that owners and operators make an effort to keep themselves informed on the topic of safety. Standards are constantly evolving and it requires vigilance to remain fully informed.

Here is a list of some of the various standards that are categorized by subject of concern:

Safety Concern	Organization and Publication Section
Altering Safety Characteristics	ANSI B20.1 paragraph 5-12.7
Backstops, Brakes	ANSI B20.1 paragraph 5.05
Cages (for ladders)	OSHA 1910.24d, 2, 5
Drive Guards	OSHA 1910.219m; 217c2b
Electrical	NEC; OSHA 1910.300
Emergency Stop Switches	ANSI B20.1 paragraph 5-11.2c
Ladders	OSHA 1910.24b
Lock Out Hazardous Energy Sources	OSHA 1910.147
Platforms	OSHA 1910.23c3; 23e; 24b
Point of Operation	OSHA 1910.212a3; 217c2b; ANSI B20.1 paragraph 5.09.1.1
Guards and Covers	
Shafting, shaft ends, couplings, guards	OSHA 1910.219; .219c4; .219l
Inlet Grates	OSHA 1910.272j
Interfacing Machines	ANSI B20.1 paragraph 5-11c

For additional copies: write Universal Industries, Inc. • PO Box 308 • Cedar Falls, IA 50613

Addresses of some of the various societies publishing rules, regulations and recommended practices:

American Society of Agricultural Engineers (ASAE)
2950 Niles Road
St. Joseph, MI 10018

American National Standards Institute (ANSI)
25 West 43rd Street, 4th Floor
New York, NY 10036
Phone: (212) 642-4900

National Fire Protection Association (NFPA)
(Publisher of the National Electrical Code)(NEC)
P.O. Box 9101
Quincy, Massachusetts 02269-9101
Phone: (800) 344-3555

American Society of Mechanical Engineers (ASME)
345 East 47th Street
New York, NY 10017

U.S. Department of Agriculture (USDA)
14th Street and Independence Avenue, S.W.
Washington, DC 20250

Factory Mutual Engr. Corp. (FM)
P. O. Box 9102
Norwood, MA 02062
Phone: (781) 440-8000

Society of Automotive Engineers (SAE)
400 Commonwealth Drive
Warrenberg, PA 15096

Underwriters Laboratories (UL)
207 East Ohio Street
Chicago, IL 60611

American Society for Testing and Materials (ASTM)
100 Barr Harbor Drive
West Conshohocken, PA 19428-2959
Phone: (610) 832-9585

OSHA, Office of Mechanical Engineering Safety Standards, Room N
3621 OSHA Dept. of Labor
200 Constitution N.W.
Washington, DC 20210

PERSONNEL CHECK FORM

RECORD OF PERSONS WHO HAVE READ AND UNDERSTOOD THIS MANUAL

The owner or employer responsible for the safe operation of this machine shall instruct all persons operating or maintaining this machine how to do so in a safe manner. This should also include good housekeeping practices.

Have the person(s) read this manual and sign in the place provided below, indicating that they understand the safety messages in the manual.

If there is some barrier to their successful reading of this manual, the manual should be read to the person(s) and questions asked to check their understanding. Have them sign below after demonstrating their understanding of the safety messages in the manual.

I have read and understood the safety messages in this manual

Name	Date	Name	Date

The employer should retain this sheet as a permanent record.

Copies of this page or of the manual can be obtained from:

Universal Industries, Inc. ♦ PO Box 308 ♦ Cedar Falls, IA 50613 ♦ Phone: (319) 277-7501 ♦ Fax: (319) 277-2318

A, B, C

Bearing Lubrication6-1

D, E, F

Decal Diagram.....8-4

Disclaimer for Misuse3-1

G, H, I, J

General Maintenance6-1

General Safety Practices.....2-3

General Specifications.....8-1

Idler Lubrication6-2

Initial Operation5-1

Installation5-1

Installation & Initial Operation.....5-1

K, L, M, N

Loading the Belt7-1

Lockable Disconnect Switch.....8-3

O, P, Q, R

Operating the Belt7-1

Parts Diagram, MPC Conveyor8-2

Parts List, Decals8-5

Parts List, MPC Conveyor8-2

Periodic Inspections6-1

Personnel Check Off Form.....10-1

Product Safety Statement.....2-1

Receiving.....4-1

Reducer & Motor Lubrications.....6-2

S, T

Safety Alert Symbols2-2

Sources of Standards & Codes9-1

Terms and Conditions of Sale1-1

U, V, W, X, Y, Z

Universal Machine Identification.....Front Cover

Unloading the Belt7-3