

BUCKET ELEVATORS

U SERIES

SINGLE TRUNK CASING WITH EASY DUMP[®]

Model	U-94ED (EASY DUMP [®])	U-250
Capacity - Free Flowing Material @ 110% Waterline Bucket Fill	75 BPH 94 ft ³ /hr 2.7 m ³ /hr	200 BPH 250 ft ³ /hr 7 m ³ /hr
Short TPH @ 50 lbs/Ft. ³	2.25	6.25
MTPH @ 50 lbs/Ft. ³	2	5
Short TPH @ 75 lbs/Ft. ³	3.5	9.3
MTPH @ 75 lbs/Ft. ³	3	10.3
Belt Speed FPM	100 (0.51m/s)	189 (0.96m/s)
Head Shaft RPM	90	170
Bucket Spacing	3-1/4" (82.55mm) Center Spacing	
Head Casing	14 Ga.	
Head Shaft Bearings	Sealed Pillow Block Tapered Roller Bearing	
Head Pulley	4-1/2" (114.3mm) Dia. w/ Vulcanized Rubber Lagging	
Buckets	3-3/4" x 3" (95.25mm x 76.2mm) HDPE Optional Carbon Steel Available	
Belting	4" (101.6mm) Wide PVC or Rubber	
Legging	16 Ga. Twin Leg Seam Welded Columns	
Boot Casing	12 Ga.	
Boot Shaft Bearings	Sealed Two Bolt Flange Ball Bearing	
Boot Pulley	4-1/2" (114.3mm) Dia. Self-Cleaning Spoke Pulley	
Construction	Powder Coated Carbon, Galvanized, or Stainless Steel	
Drive Package	Optional	
Motor	Optional	
Lining Options	Consult Factory	

(EASY DUMP[®] speed, the speed suggested for gentle handling, is only guaranteed on the lowest capacity for each elevator).

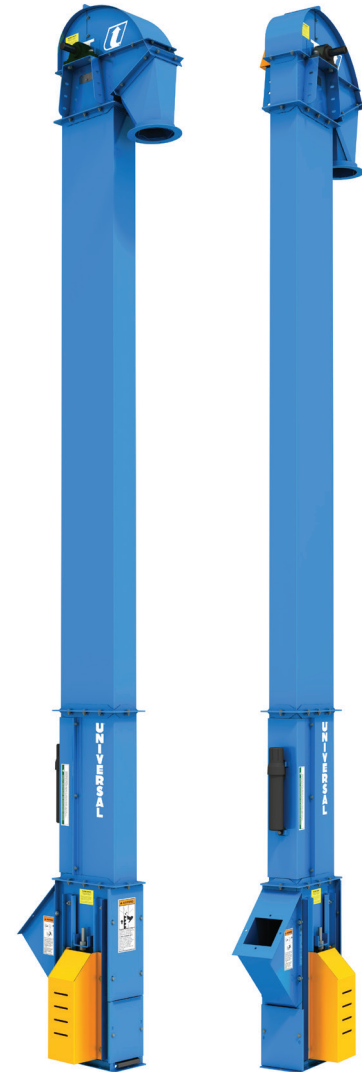

U Series bucket elevators utilize a single trunk casing and are built with thicker steel to handle corrosive, abrasive and hostile materials.

Available in powder coated carbon, stainless, or galvanized steel with buckets available in HDPE, carbon steel, nylon and urethane.

WHAT THE INDUSTRY IS BUILT AROUND

800.553.4446 | WWW.UNIVERSALINDUSTRIES.COM

BUCKET ELEVATORS | U SERIES

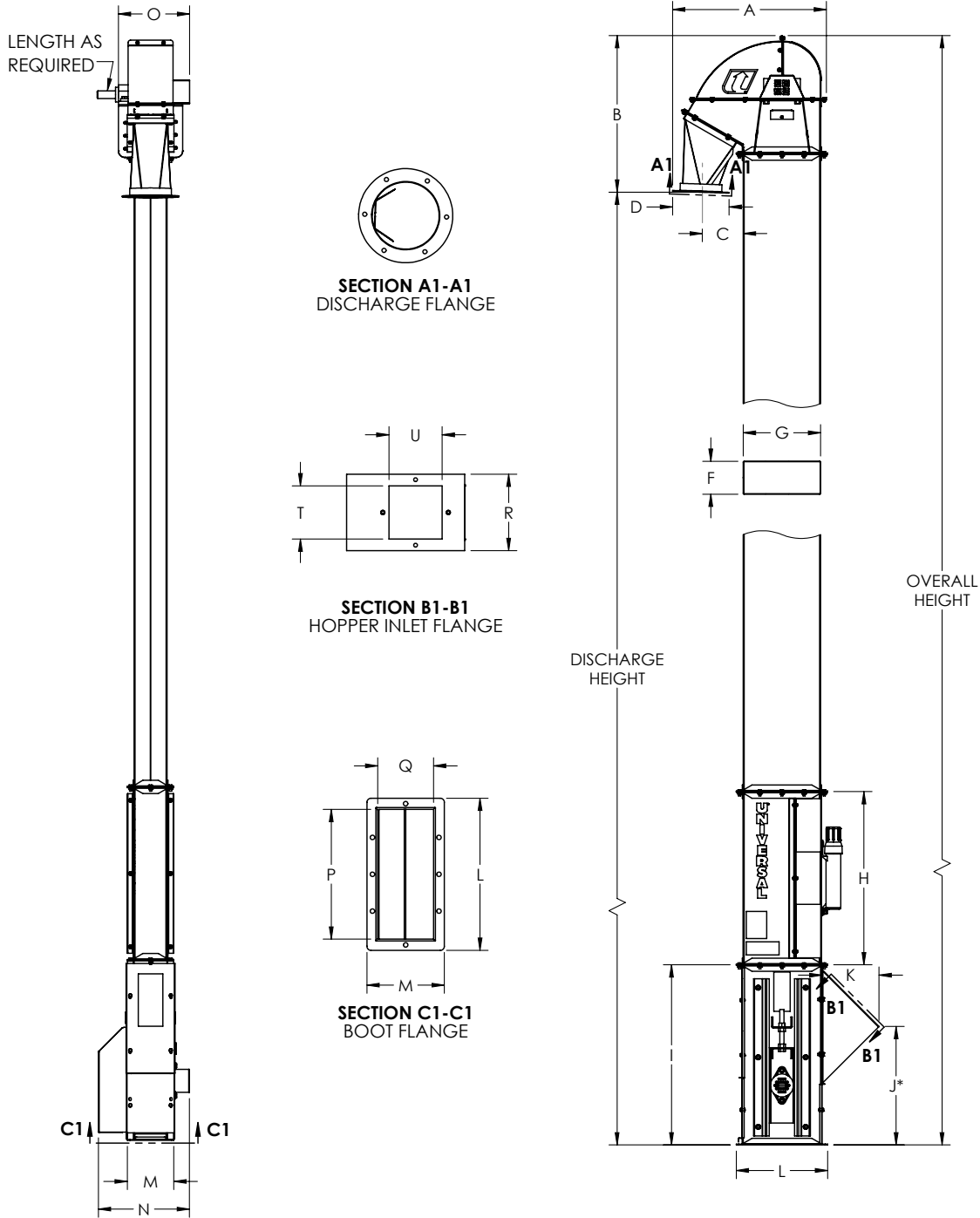

Unit	A	B	C	D	F	G	H	I	J	K	L	M	N	O	P	Q	R	T	U	W
in	23.5	23.9	6.3	8.6	5	11.8	26.4	27.5	18.0	8.8	13.9	7.1	13.9	10.9	11.9	5.1	7	4.9	4.9	6.1
mm	597	607	159	219	128	300	672	699	458	224	354	180	353	276	302	129	178	124	124	156



NOTE: Unit application, location and specifications determine the type, quantity and/or placement of electrical, electrical safety or other safety controls required. Whether these controls are supplied by Universal Industries or another supplier, all OSHA safety and health standards, the National Electrical Code and local codes must be met and followed. Because we constantly strive to provide the finest material handling equipment, establishing industry standards, specifications must remain subject to change without notice.