

BUCKET ELEVATORS

UNIMAX[®] 36

HIGH CAPACITY CENTRIFUGAL DISCHARGE ELEVATORS

Model	UniMAX [®] 36
Capacity - Free Flowing Material @ 110% Waterline Bucket Fill	9,500 - 13,000 BPH 11,875 - 16,250f ³ /h 336 - 460 m ³ /h
Short TPH @ 50lbs/ft ³	297 - 406
MTPH @ 50lbs/ft ³	270 - 369
Belt Speed FPM	615 - 800
Belt Speed m/s	3.12 - 4.06
Head Shaft RPM	65 - 85
Bucket Spacing	10" (254mm)
Head Casing	12 Ga. Hoods & 10 Ga. Lower Head
Head Shaft Bearing	Sealed Pillow Block Type E-Xtra Bearings Optional Pillow Block Type EXL Bearings
Head Pulley	36" (914.4mm) Dia. Pulley with Slide Lagging
Buckets	14" x 8" (355.6mm x 203.2mm) HDPE Buckets Standard
Belting	15" (381mm) Wide Rubber Conti-Tech Pathfinder [®]
Legging	12 Ga. Twin Leg Seam Welded Columns Optional 10 Ga.
Boot Casing	1/4" (6.35mm)
Boot Shaft Bearing	Sealed Pillow Block Ball Bearing Optional 4 Bolt Flange Ball Bearing
Boot Pulley	36" (914.4mm) Dia. Self-Cleaning Wing Pulley
Steel Construction	Powder Coated Carbon, Hot Dipped Galvanized, or Stainless
Drive Package	Optional
Motor	Optional
Lining Options	AR Steel, Ceramic, and Urethane
Optional Accessories	Shovel Pocket, Rack & Pinion Cleanout Slides, Cup Fill Inspection Door, Pressure Relief Panels



Engineered to meet the most strict industry standards. The elevator head, boot, and intermediate sections have been designed with adequate space for buckets and belt to travel un-impeded throughout the system.

WHAT THE INDUSTRY IS BUILT AROUND

800.553.4446 | WWW.UNIVERSALINDUSTRIES.COM

BUCKET ELEVATORS | UNIMAX® 36

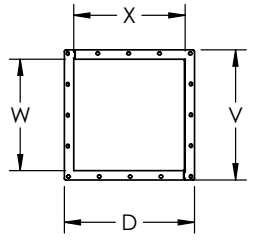
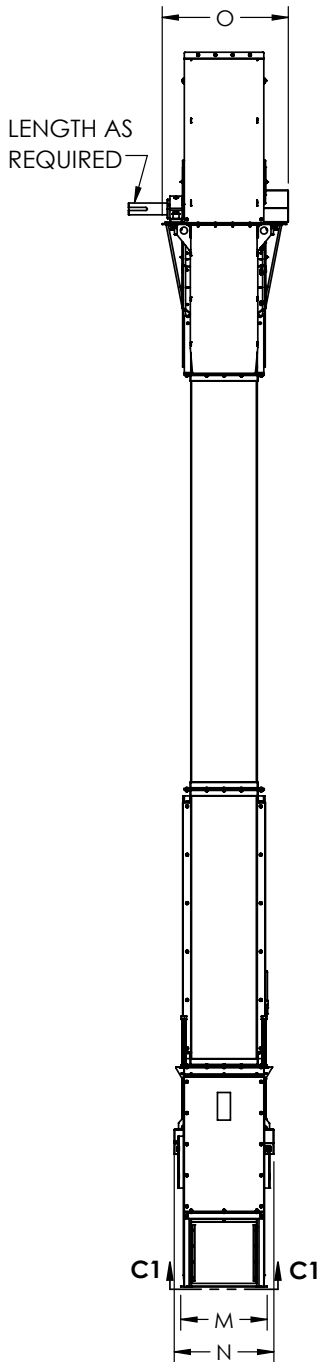

SECTION A1-A1
DISCHARGE FLANGE

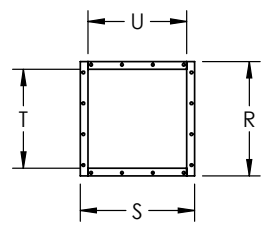

SECTION B1-B1
HOPPER INLET FLANGE

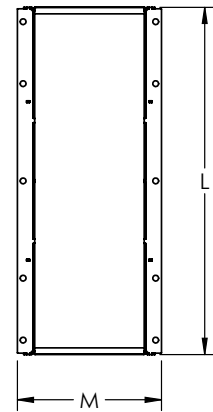

SECTION C1-C1
BOOT FLANGE

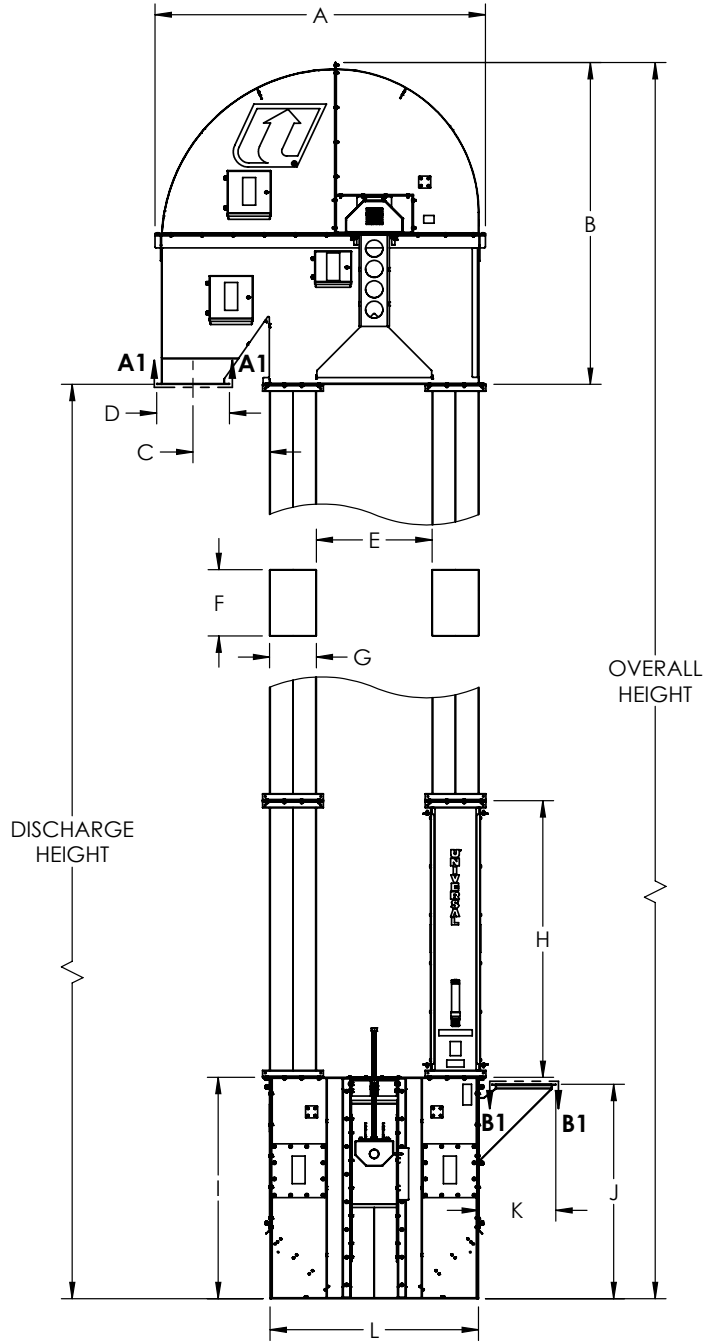

Unit	A	B	C	D	E	F	G	H	I	J	K	L	M	N	O	R	S	T	U	V	W	X
in	95.5	93.1	22.2	21.1	33.5	19.2	13.5	80	64	62	22.4	60.3	25	29	36.5	18.5	18.5	16	16	21.1	18.1	18.1
mm	2426	2365	564	535	850	488	344	2032	1626	1575	568	1530	635	737	927	470	470	406	406	535	459	459



NOTE: Unit application, location and specifications determine the type, quantity and/or placement of electrical, electrical safety or other safety controls required. Whether these controls are supplied by Universal Industries or another supplier, all OSHA safety and health standards, the National Electrical Code and local codes must be met and followed. Because we constantly strive to provide the finest material handling equipment, establishing industry standards, specifications must remain subject to change without notice.